

The Price Alternative



Series OSX Light Duty Pneumatic Thruster Slide

- 5 bore sizes
- 7 travel lengths
- Dual bore



www.phdinc.com
(800) 624-8511

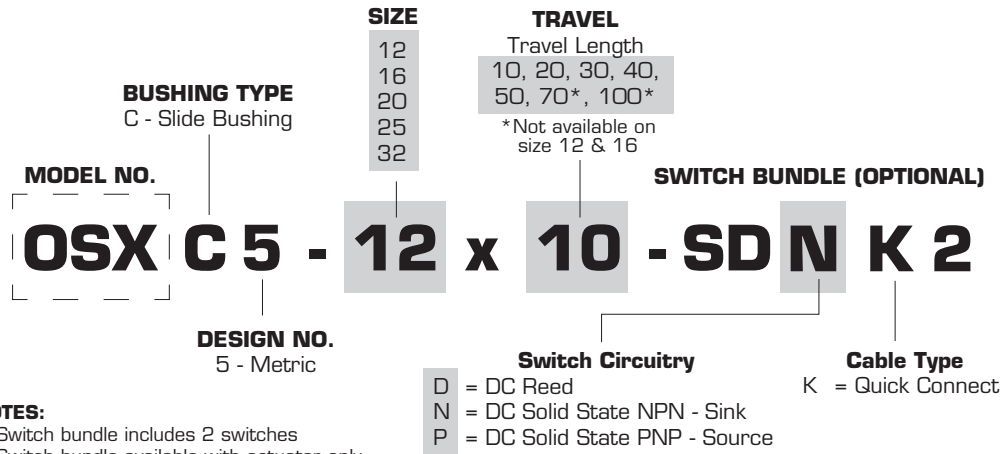

- NOTES:**
 1) Switch bundle includes 2 switches
 2) Switch bundle available with actuator only
 3) Switches available in Quick Connect only
 4) Magnets standard for switch sensing

Switches	
Part Number	Description
86725-0	Reed DC 5-30 V, 50mA, Quick Connect
86726-0	Sink Type (NPN), DC 5-30 V, 50mA, Quick Connect
86727-0	Source Type (PNP), DC 5-30 V, 50mA, Quick Connect

Includes one switch

Cordsets	
Model Number	Cable Length
63549-02	78.74 in [2 m]
63549-05	196.85 in [5 m]

Includes one cordset

BENEFITS

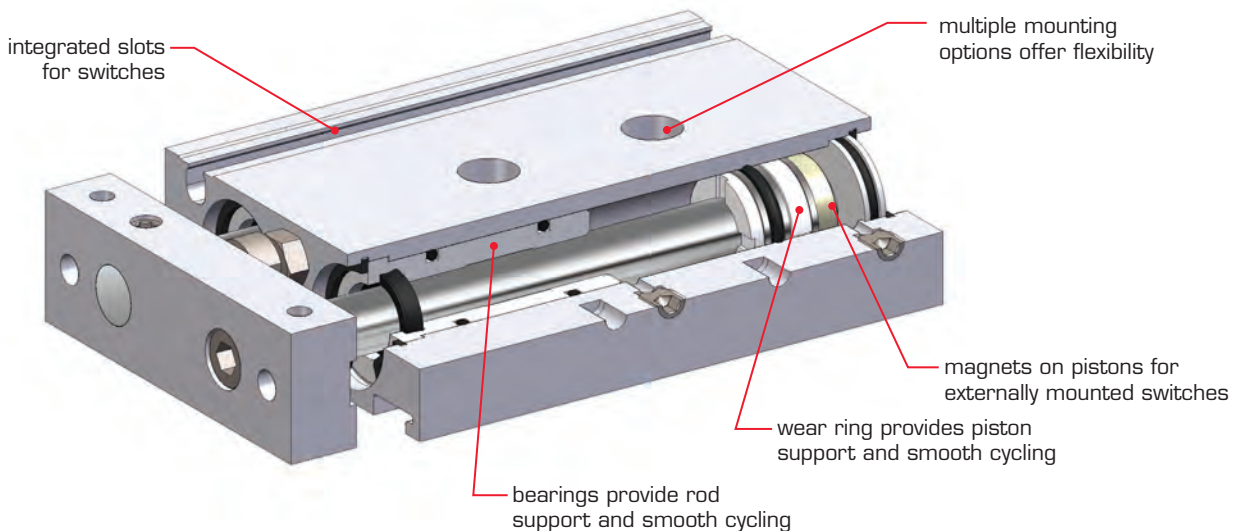

- Standard shock pads reduce end of travel impact
- 5 bore sizes with up to 7 travel lengths available to fit variety of applications
- Travel adjustment on retract
- Magnets standard for switch sensing capability
- Smooth linear motion at twice the thrust of a single bore size
- Drop-in metric mounting to match global standard
- Sizes 12 and 16 are drop-in compatible for competition sizes 10 and 15.

Specifications	Series OSX Slide
Maximum Air Pressure	7 bar [101 psi]
Operating Temperature	5° to 60°C [41° to +140°F]
Velocity	30 to 700 mm/sec [1 to 27 in/sec]
Rated Life	3 million cycles
Lubrication	Factory lubricated for rated life

Size	Rod Size	Effective Area		
		Direction	mm ²	in ²
12	6	Extend	226	0.350
		Retract	170	0.264
16	8	Extend	402	0.623
		Retract	346	0.536
20	10	Extend	628	0.973
		Retract	471	0.730
25	12	Extend	982	1.522
		Retract	756	1.172
32	16	Extend	1608	2.492
		Retract	1206	1.869

Size	Unit Weight by Travel													
	10		20		30		40		50		70		100	
	kg	oz	kg	oz	kg	oz	kg	oz	kg	oz	kg	oz	kg	oz
12	0.14	4.9	0.16	5.6	0.18	6.3	0.20	7.1	0.22	7.8	—	—	—	—
16	0.23	8.1	0.26	9.2	0.28	9.9	0.31	10.9	0.34	12.0	—	—	—	—
20	0.39	13.8	0.43	15.2	0.47	16.6	0.50	17.6	0.54	19.0	0.63	22.2	0.73	25.7
25	0.62	21.9	0.67	23.6	0.73	25.7	0.78	27.5	0.84	29.6	0.96	33.9	1.11	39.1
32	1.10	38.8	1.18	41.6	1.27	44.8	1.35	47.6	1.44	50.8	1.66	58.5	1.88	66.3

Size	Maximum Lateral Loads by Travel													
	10		20		30		40		50		70		100	
	kg	lb	kg	lb	kg	lb	kg	lb	kg	lb	kg	lb	kg	lb
12	0.23	0.50	0.20	0.44	0.15	0.33	0.13	0.29	0.12	0.26	—	—	—	—
16	0.54	1.20	0.48	1.06	0.40	0.88	0.35	0.77	0.30	0.66	—	—	—	—
20	0.91	2.00	0.85	1.87	0.74	1.63	0.65	1.43	0.58	1.28	0.40	0.88	0.30	0.66
25	1.48	3.25	1.35	2.98	1.18	2.60	1.03	2.27	0.90	1.98	0.68	1.50	0.52	1.15
32	2.40	5.29	2.25	4.96	1.95	4.30	1.75	3.86	1.55	3.42	1.18	2.60	0.90	1.98

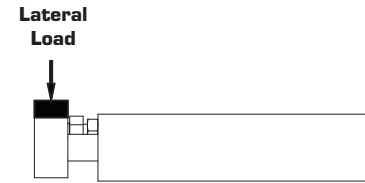

MAXIMUM ALLOWABLE KINETIC ENERGY

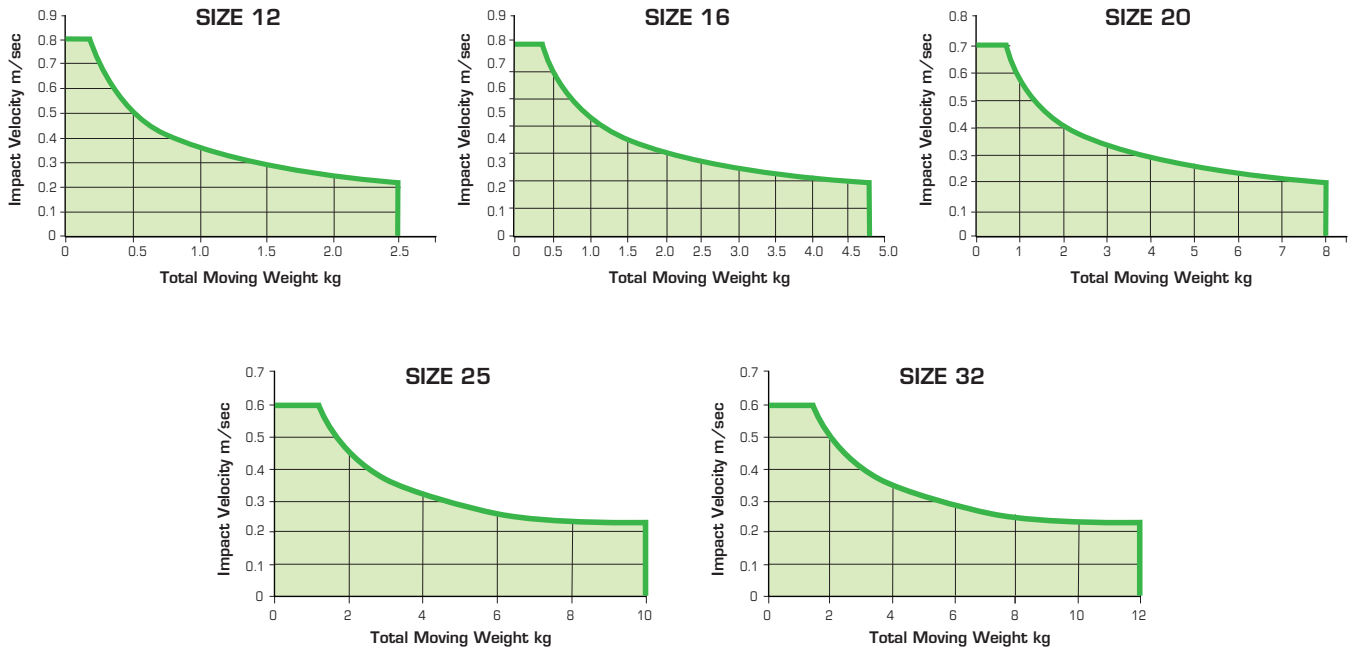

Size	Recommended Mounting Torques									
	Body Thru & C-Bore		Body Bottom Threads Unit (Mounting)		Body Side Threads Unit (MTG)		Tool Plate Face (Tooling MTG)		Tool Plate Top & Bottom (Tooling MTG)	
	Nm	in-lb	Nm	in-lb	Nm	in-lb	Nm	in-lb	Nm	in-lb
12	1.7	15	2.8	25	1.7	15	2.8	25	1.7	15
16	2.8	25	4.5	40	2.8	25	4.5	40	2.8	25
20	4.5	40	7.5	66	2.8	25	4.5	40	2.8	25
25	7.5	66	18.1	160	4.5	40	7.5	66	4.5	40
32	7.5	66	18.1	160	4.5	40	7.5	66	4.5	40

NOTES:
 1) Assumes use of at least 75% of full thread depth.
 2) Assumes use of high strength steel socket head cap screws.
 3) PHD recommends use of threadlocker.

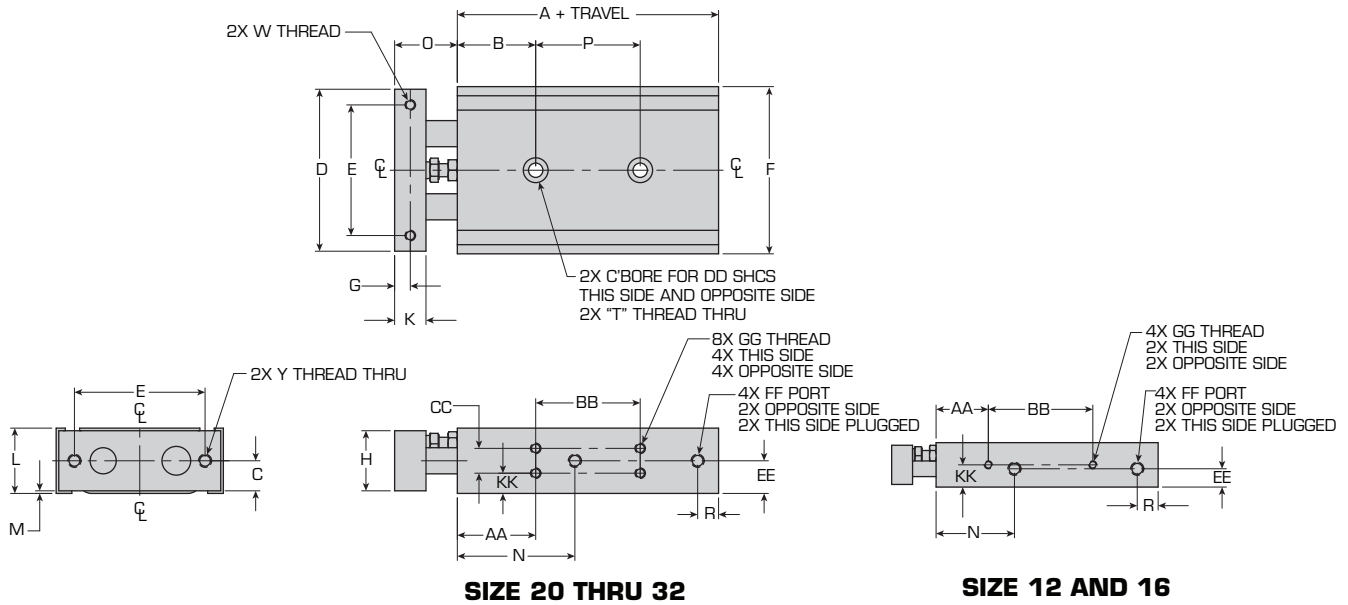

NOTES:

- 1) Dimensions are in mm
- 2) Designated centerline ϕ is centerline of unit.

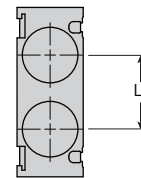
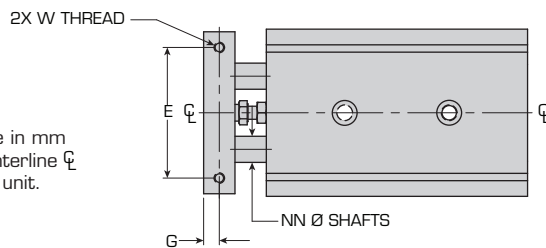

LETTER DIM	SIZE												
	12		16		20			25			32		
	10 & 20	30, 40 & 50	10 & 20	30, 40 & 50	10 & 20	30, 40 & 50	70 & 100	10 & 20	30, 40 & 50	70 & 100	10 & 20	30, 40 & 50	70 & 100
A	55 + TRAVEL		60 + TRAVEL		70 + TRAVEL			72 + TRAVEL			82 + TRAVEL		
B	20		30		30			30			30		
C	8		9		11.5			14			18		
D	44		56		62			78			96		
E	35 ± 0.2		45 ± 0.2		50 ± 0.2			60 ± 0.2			75 ± 0.2		
F	46		58		64			80			98		
G	4		5		6			6			8		
H	16		18		23			28			36		
K	8		10		12			12			16		
L	18		20		25			30			38		
M	1		1		1			1			1		
N	30		38.5		45			46			56		
O	17		19		24			24			30		
P	30	40	25	35	30	40	60	30	40	60	40	50	70
R	8		8		8			9			10		
T	M4 x 0.7		M5 x 0.8		M6 x 1			M8 x 1.25			M8 x 1.25		
Y	M4 x 0.7		M5 x 0.8		M5 x 0.8			M6 x 1			M6 x 1		
W	M3 x 0.5 DP 5		M4 x 0.7 DP 6		M4 x 0.7 DP 6			M5 x 0.8 DP 7.5			M5 x 0.8 DP 8		
AA	20		30		30			30			30		
BB	30	40	25	35	30	40	60	30	40	60	40	50	70
CC	-		-		9.5			13			20		
DD	M3		M4		M5			M6			M6		
EE	10		10		12.5			15			19		
FF	M5		M5		M5			G 1/8			G 1/8		
GG	M3 x 0.5 DP 4.5		M4 x 0.7 DP 5		M4 x 0.7 DP 5.5			M5 x 0.8 DP 7.5			M5 x 0.8 DP 7.5		
KK	8.5		10		7.75			8.5			9		
LL	19		25		28			35			44		
NN	Ø 6		Ø 8		Ø 10			Ø 12			Ø 16		

All dimensions are reference only unless specifically toleranced.