

Your Source for

# Parts Handling Systems

*From concept to installation, commitment to quality, delivery and support for your productivity*

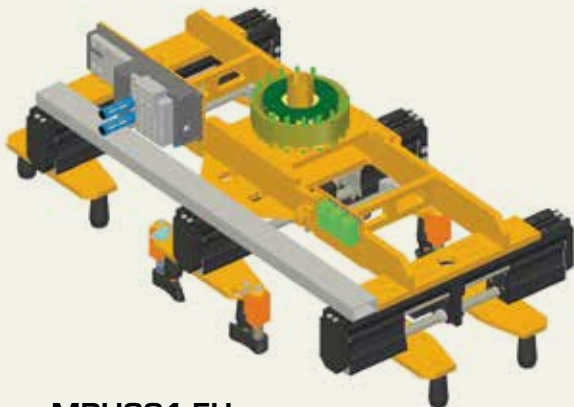
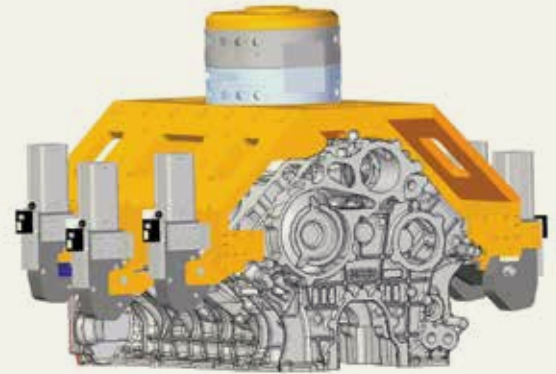
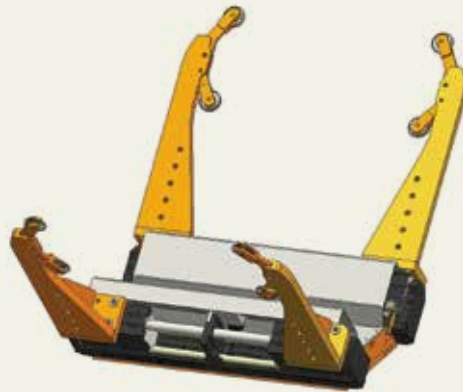
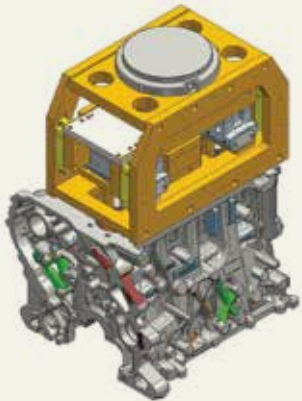
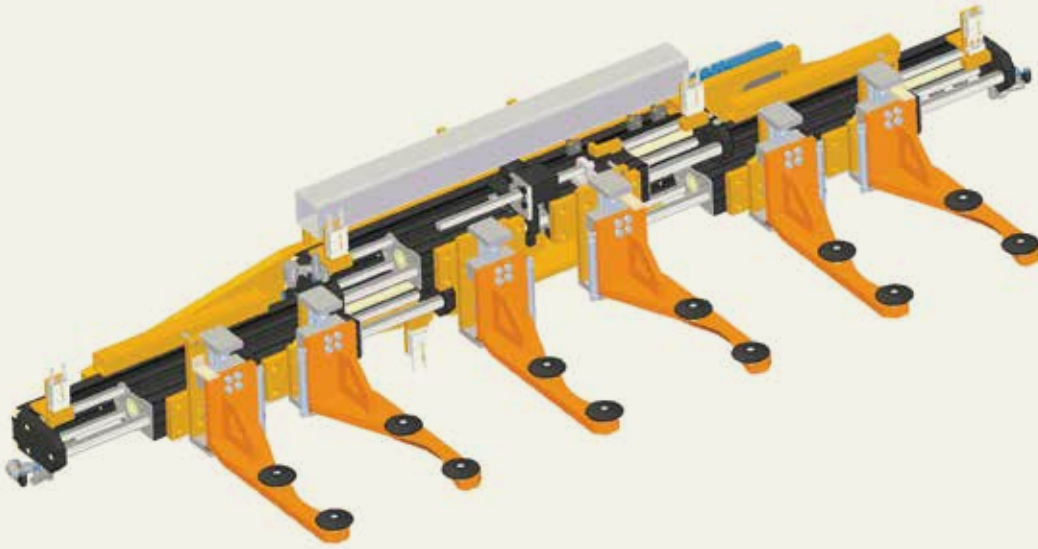

MPHS01-EU

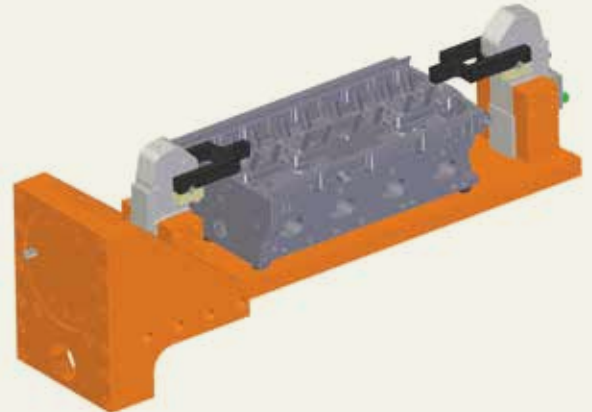

PHD is a member of the  
MAC Distributor Network

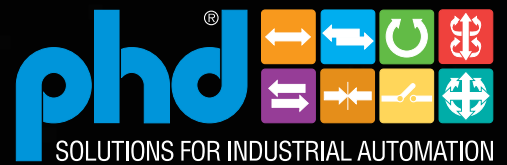

SOLUTIONS FOR INDUSTRIAL AUTOMATION

[www.phdinc.com](http://www.phdinc.com)

# PHD's commitment to quality, support, and the engineering design experience to ensure success



## OUR STANDARD PRODUCTS

- Cylinders
- Escapements
- Grippers
- Linear Slides
- Rotary Actuators
- Clamps
- Multi-Motion Actuators
- Switches & Sensors

For over 60 years, PHD, Inc. has been a leading manufacturer of pneumatic, hydraulic, and electric powered devices helping companies across all industries optimize automation and manufacturing processes. Our broad product portfolio, unique options, and made-to-order manufacturing processes set us apart in the industry.

Our full line of automation components provides flexibility, durability, and repeatability while welcoming the challenge of many different types of operating environments.

PHD has been developing grippers since the early 1980's. Over the years working with our customers and distributors, we have grown an extensive line of gripping products to support industry needs.

Additionally, we extend our engineering capabilities and industry experience to our customers by providing design and development of parts handling systems as needed. See the overview below.



## Three Levels of System Development PHD Provides

### Your Robot, Your Way

*Your Robot Your Way utilizes PHD's vast experience in design and production of end effectors and systems to deliver customized solutions to assist in maximizing robot effectiveness.*

### 1 PHD Designs & Creates CAD Files

PHD will determine the exact gripper and design the tooling and accessories needed to handle the specific parts to meet the requirements specified. We provide CAD files to manufacture the tooling and accessories required for the complete PHD Gripper system.

### 2 PHD Designs, Makes Parts, & Provides Kits

In the event the customer would prefer more assistance, PHD will provide the grippers/actuators along with the tooling, fixturing, and hardware in a kit form so the customer can assemble the system.

### 3 PHD Designs, Builds, & Provides System

Finally, if a customer wants the system **designed, manufactured, and assembled ready for installation, PHD will deliver the system**, Your Robot, Your Way. The following pages show a few examples of systems developed. Consult PHD Applications Engineering for a consultation on your next project.



# Double Rim Handling System Loads/Unloads for Improved Process Time

## APPLICATION

- The rims are only pre-painted. The customer's machines mill off the paint to expose the aluminum surface.
- The hard clear finish coating will be done after the milling process.

## CUSTOMER REQUIREMENTS

- Pick up the rims from a conveyor and load the rim into the milling machine in a fully automated manner within a certain cycle time.
- It is very important that the aluminum does not get scratched.
- Pick up the rims with one robot/milling machine.

## PHD'S SOLUTION

PHD suggested to use a double gripper, one side for unloading and the other for loading the milling machine. This makes the machine more efficient due to less waiting time.

Rim sizes:	14" – 21"
Jaw travel:	2 x 160 mm
Contact area:	drop center
Contact points:	wheels with PU coating
Gripper weight:	max. 105 kg
Gripper width:	max. 800 mm

The Series GRR was used in this application, but a Series EGRR electric gripper could provide an even bigger benefit by saving cycle time. By using the EGRR, the tooling can be pre-positioned. This makes the gripper faster when loading and unloading; therefore, the machine is more efficient.



*GRR Grippers shown without guards which protect the guide shaft from machine chips*



*Anti-scratching rollers*



*Double gripper solution*

# Rim Gripper System to Load/Unload a Milling Machine

## APPLICATION

- Loading and unloading of milling machine
- Gripping system requires mounting a gantry robot
- 19" - 21" rims
- Maximum weight 35 kg/rim
- Load milling machine with casted rim
- Milling machine finishes approximately 50% of rim

## CUSTOMER REQUIREMENTS

- Load and unload milling machine with two gripping systems
- Gripper should rotate rim 180°

## PHD'S SOLUTION

The system design utilizes a Series GRR Gripper with tooling and Series RID Rotary Actuators that perform the rim 180° rotation. After loading the rim in the milling machine, there is a three-position Series SLD Slide which presses against the rim (from above) to hold it in position until it is clamped by the milling machine. The PHD solution completes the entire process with one system.



# Double Rim Handling System for Coating Process

## APPLICATION

- In the painting station, the rims are taken from the color powder chain to the heating chain.
- Competitor's gripper designed for 21" rims did not have enough grip force for the heavier 21" and 22" rims, so the customer lost heavy rims on a regular basis. Since the customer wanted to speed up the whole painting process (from 170 to 240 rim/hour), the competitor's gripper was not fast enough.
- Due to the small stroke of the competitor's gripper, they had to grip at the edge of the rims which sometimes caused marks in the paint thus causing it to be reworked.

## CUSTOMER REQUIREMENTS

- Complete gripping system for powder coating station
- Replacement for double gripper in rim painting process.

## PHD'S SOLUTION

The PHD system incorporates two Series GRR Grippers with special tooling. This system handles both rim sizes. Additionally, the new system grips the rims without damaging the powder coating; thus increasing the efficiency of the process and reducing scrap. Also, the gripper was equipped with a Z-alignment to prevent damage on the rim/powder when placing it on the conveyor.

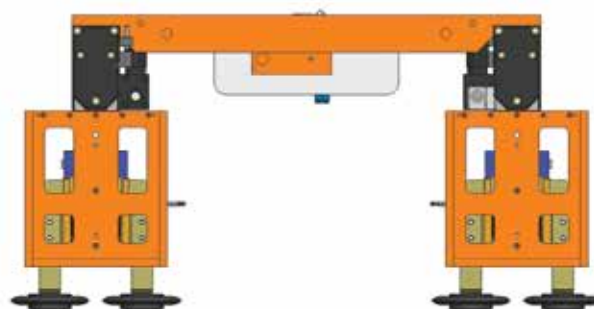

*The installed gripper system runs extremely well as designed.*

# Engine Block Mill Load/Unload

## APPLICATION

- Handle 1,6 and 2,0 liter engine blocks.
- Load and unload lathe, drilling and milling machines.
- Maximum weight approximately 30 kg.  
The gripper is attached to Fanuc robots for maximum 130 kg.
- Grip the engine blocks going through the outer piston bores without damaging the bore surface and center the part by two cones in bore 2 and 3.

## CUSTOMER REQUIREMENTS

- Turn the gripper 90 degrees to grip the part internally from side to side.
- Total gripper dimensions stay within the dimensions of the engine block.

## PHD'S SOLUTION

The gripper remained in all outside dimensions (length/width) within the dimensions of the engine blocks. The gripper system remained below 40 kg. The gripper system was complete for direct mounting on the Fanuc robot and provided rigid and stable centering in the middle piston bores. In case of air loss, the grippers contain a mechanical grip force safety actuated by internal springs.

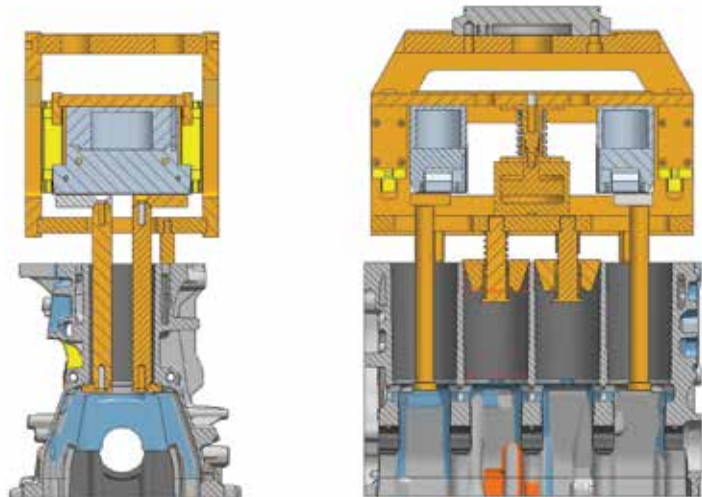

# Cylinder Head Assembly Gripper System

## APPLICATION

- The gripper is mounted to a 6 axis robot handling 4-cylinder aluminum heads (approximately 10 kg).
- The valve seats are pressed into the cylinder head while it is gripped.
- The bottom and top sides of the cylinder head must be accessible.
- Open and close detection
- The cylinder head must rest on 4 contact plates.
- 2 index pins to center the part
- Repeatability and stability:  $\pm 0,02$  mm
- The cylinder head is supported while the seats are pressed in.
- Special clearance beneath the gripper for the conveyor.
- A cone at the end of the gripper is required to be able to check the position of the gripper with a reference point.
- The gripper must lock in case the air drops off.

## CUSTOMER REQUIREMENTS

- Grip and handle cylinder head during assembly



Cylinder head

## PHD'S SOLUTION

The solution was a lightweight gripper with a very high stability. PHD met the customer's requirements in terms of safety and repeatability with a mechanical locking mechanism for safety in case of air loss. The robust base plate that holds the part during the assembly process provides a repeatability of  $\pm 0,02$  mm due to indexing the part.

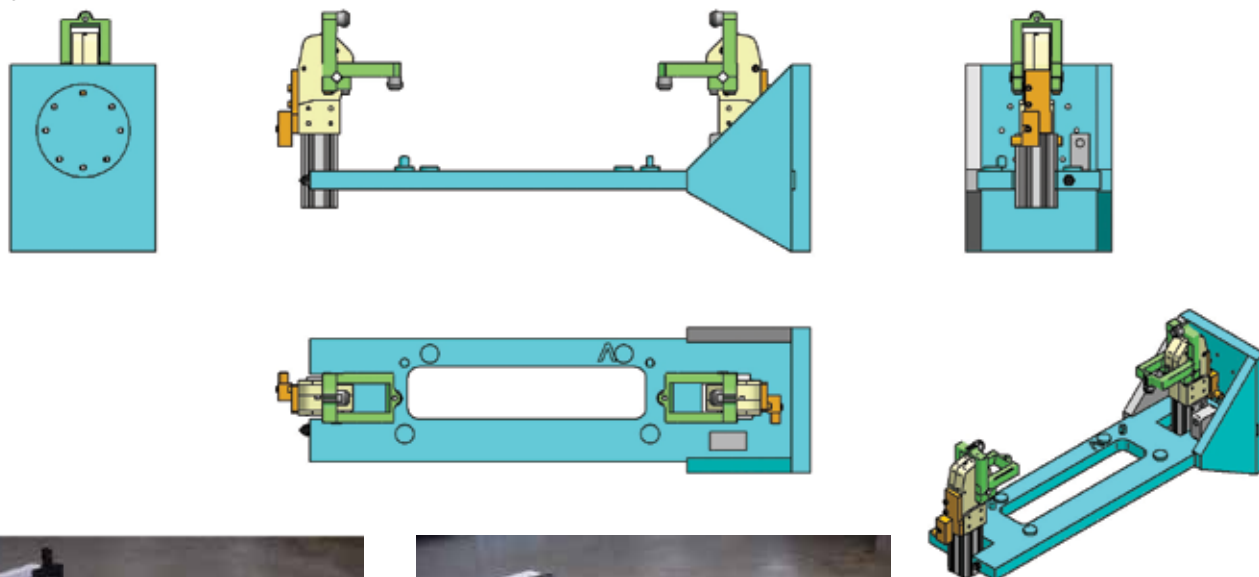

# Crankshaft Handling System

## APPLICATION

- Challenges: not enough grip force, gripper size was too large, short lifetime, and several grippers for different crankshaft sizes were needed. In the past, the grippers had to be changed every 3 months due to contamination.
- Production process: From the blank shaft to the finished crankshaft.
- Requires safety device to hold the crankshaft in case the air drops off



## CUSTOMER REQUIREMENTS

- Handle crankshafts in different stages of production
- One gripper for as many different crankshaft (8 kg to 28 kg) sizes as possible
- Enough grip force to handle all crankshaft sizes
- Cost-effective gripper
- Withstand the coolant dirt from the grinding and milling machines
- Extended life expectancy to reduce downtime and maintenance (5 million cycles)

## PHD'S SOLUTION

The Series 5300 Angular Gripper mechanism is much more robust than a parallel mechanism. This gripper has a sealed jaw driving mechanism. There is enough grip force to handle all crankshaft sizes. Downtime was reduced. The angular gripper system reduced cost for the customer.

