

# MAGNETIC GRIPPER

MODEL 86560



*No expensive tooling*

*Variability of part pickup*

*Compact size*

*No electric lines required*

MAGGRIP14A



PHD is a member of the  
MAC Distributor Network

**phd**   
SOLUTIONS FOR INDUSTRIAL AUTOMATION

PHD, Inc. • P.O. Box 9070 • Fort Wayne, IN 46899 • (260) 747-6151 • FAX (260) 747-6754  
[www.phdinc.com](http://www.phdinc.com) • [phdinfo@phdinc.com](mailto:phdinfo@phdinc.com)

# ORDERING DATA & SPECIFICATIONS: 86560 Magnetic Gripper

## INDEX:

Ordering Data & Specifications

Page 2

Benefits

Page 3

Dimensions

Page 4

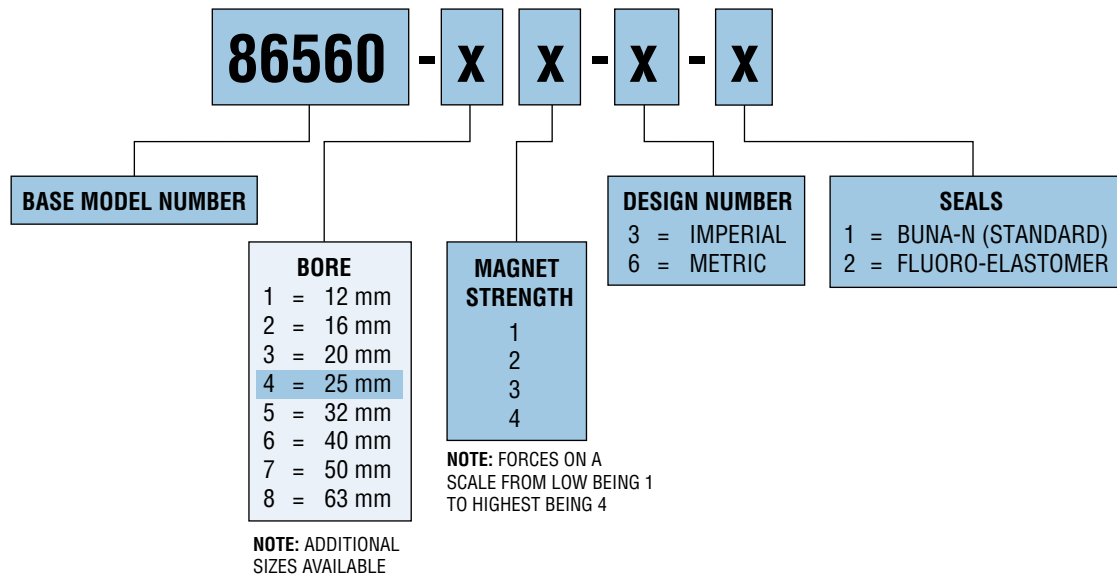

PHD MODEL#	MAX PULL FORCE (lb)
86560-41-x-1	0.500
86560-42-x-1	2.500
86560-43-x-1	4.500
86560-44-x-1	11.000

**NOTE:** MAX PULL FORCE IS BASED ON STATIC APPLICATION, EACH APPLICATION AND DYNAMIC MOTION MUST BE TESTED AND REVIEWED TO DETERMINE ACTUAL FORCE REQUIREMENTS.

# BENEFITS: 86560 Magnetic Gripper

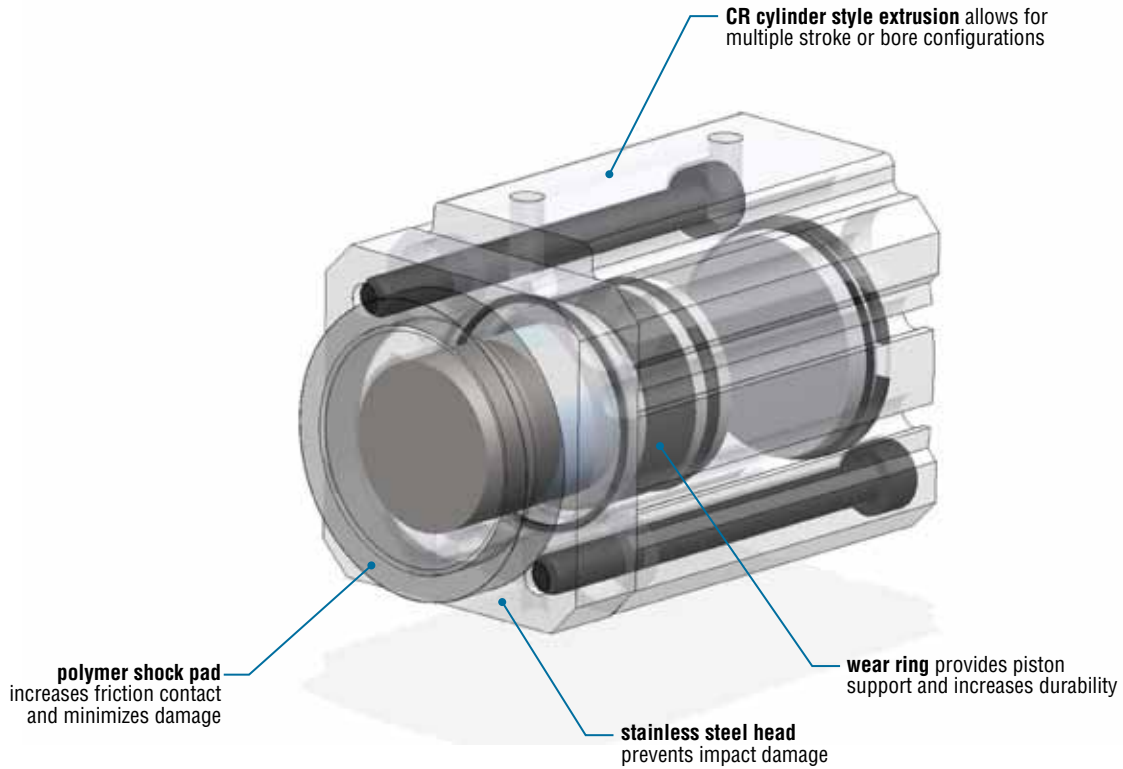

## BENEFITS

- No expensive tooling
- 1 less axis of motion
- Variability of part pickup
- Compact size
- Stainless steel cap improves durability
- Multiple sizes available based on customer application
- Cost-effective solution
- No electric lines required



# DIMENSIONS: 86560 Magnetic Gripper

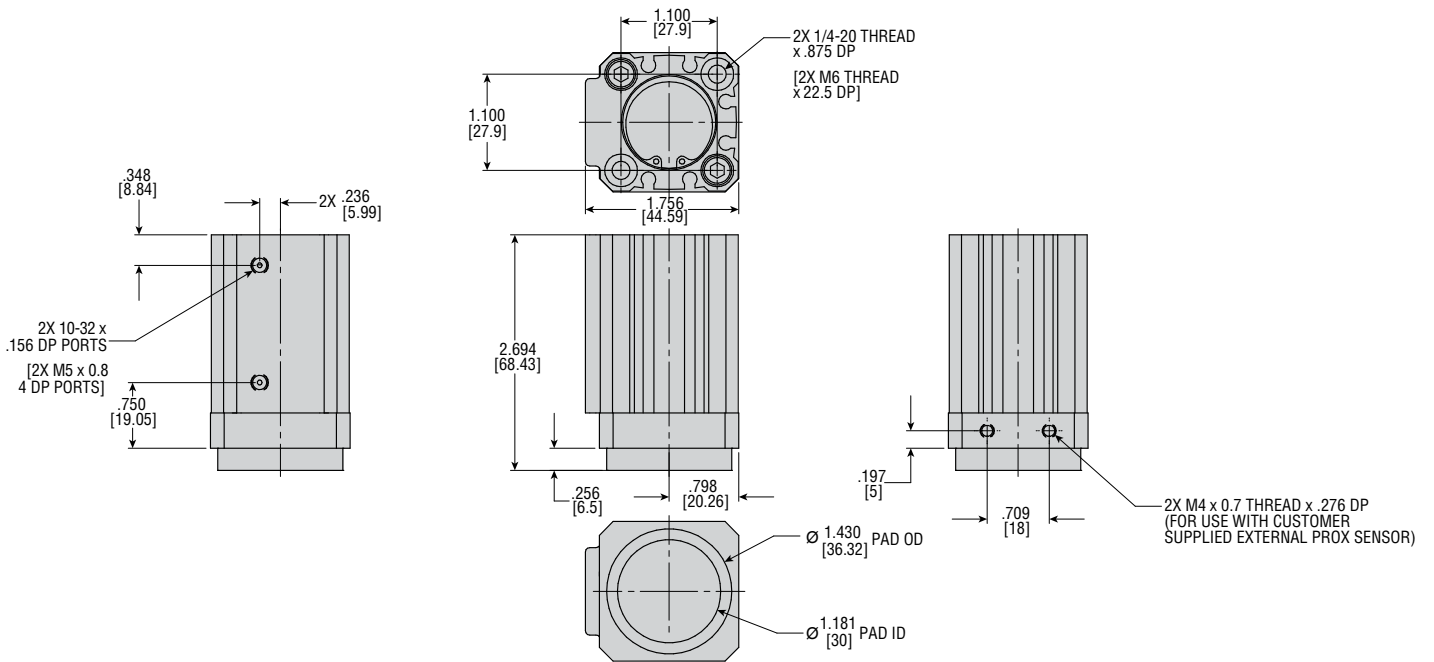
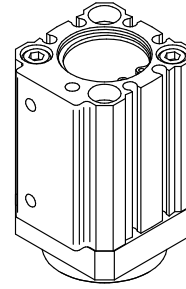

**PHD, Inc.**  
 9009 Clubridge Drive  
 P.O. Box 9070, Fort Wayne, Indiana 46899 U.S.A.  
 Phone (260) 747-6151 • Fax (260) 747-6754  
 www.phdinc.com • phdinfo@phdinc.com

**PHDinEurope GmbH**  
 Arnold-Sommerfeld-Ring 2  
 52499 Baesweiler, Germany  
 Tel. +49 (0)2401 805 230 • Fax +49 (0)2401 805 232  
 www.phdinc.com • info@PHDinEurope.de