

FILLING & RELATED PROCESS IMPROVEMENTS

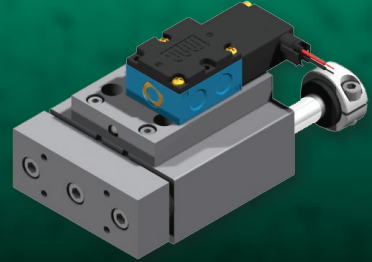
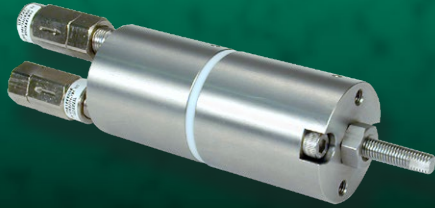

INCREASE PRODUCTION • REDUCE MAINTENANCE • REDUCE DOWNTIME • REDUCE SCRAP

DEPALLETIZING SOLUTION

FILLER CYLINDERS

VOLUMETRIC PUMP

CAM FOLLOWER WHEELS

EJECT SLIDE

CASE TURNING SOLUTIONS

We understand



your unique requirements

Focused on the specific needs of the plastic packaging industry, PHD has worked with a wide range of continuous extrusion OEMs and user accounts to produce a variety of improved solutions for the industry.

Our components are the actuators of choice. Designed for long life, PHD products keep your blow molding lines running while increasing productivity and reducing downtime and scrap.

We also offer the added benefit of our rebuild program which refurbishes your existing PHD components, enabling even longer service life and savings.

See page 15 for more information.



To request more literature, visit www.phdinc.com/resources/inforequest/

Easy Drop-in

With longer life, reduced maintenance, and reduced downtime

We offer a wide variety of direct replacement components. Our drop-in components save you money by reducing costly production downtime and maintenance costs.

Many of our components provide up to twice the life of the original unit. This means longer run time for higher production and higher profits.

Superior Delivery

FASTER
delivery than competitor

Excellent delivery saves you money by getting you back to business faster.

Unique Solutions

Special Requirements

PHD offers a variety of components already designed to fit unique requirements. If your application requires a modified component from outside our large database of designs, our team is ready to help. We welcome special requests, regardless of quantity or frequency of order. See page 15.

Rebuild Program

Return to Service

Our products can be rebuilt and put back in service for continued savings. Plus you will receive a "like new" warranty. See page 14 for more information.



CONTENTS

PRE-FILL

Slip Sheet Gripper Assembly 4
Depalletizing Solution

FILL

Machine Lift Cylinder 7
'K' Style Volumetric Filler Machine Component

2 Position Filler Cylinder 8
'K' Style 55 and 60 mm Bolt Spacing Component

Series FCB Filler Cylinder 9
'K' Style 45 Component

Volumetric Pump 10
Specialized Filling Application

Cam Follower Wheels 11
Mechanical Filling Application

DOWNSTREAM

Eject Slide 12
Empty and Full Container Ejection System

Case Turners 13
Palletizing Solutions

OTHER

Rebuild Program 14
Return your unit to service and get a 12 month "like new" warranty

Unique Solutions® 15
PHD offers unlimited design capabilities to fit your needs

Other Solutions 16

Any marks or names referenced herein are either registered trademarks or trademarks of their respective owners. No association with or endorsement of any company, organization, or product is intended or should be inferred.

Slip Sheet Gripper Assembly

15 Different Combinations Available

MAJOR BENEFITS

- Modular assembly consisting of a GRM Clamp, an SBx Slide, and one transition plate
- The combination of clamp and slide is a robust design, providing long life
- The clamp provides a wide opening so slip sheets are not missed and a positive lock in the last six degrees of travel to firmly hold the slip sheet even when air pressure is removed
- The slide provides a rugged and rigid support mechanism utilizing two bushings and stout guide shafts for maximum load carrying capability
- Modular design for quick installation and easy maintenance
- Increased production and reduced maintenance costs are achieved
- Factory rebuild available which features a new part warranty from date of rebuild
- Local/Worldwide MDN network sales, service, and support
- PHD's over 60 years of pneumatic actuator experience

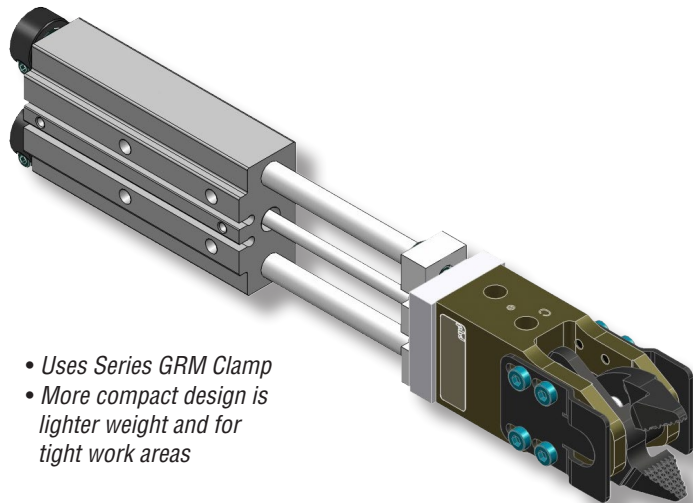

- Uses Series GRM Clamp
- More compact design is lighter weight and for tight work areas

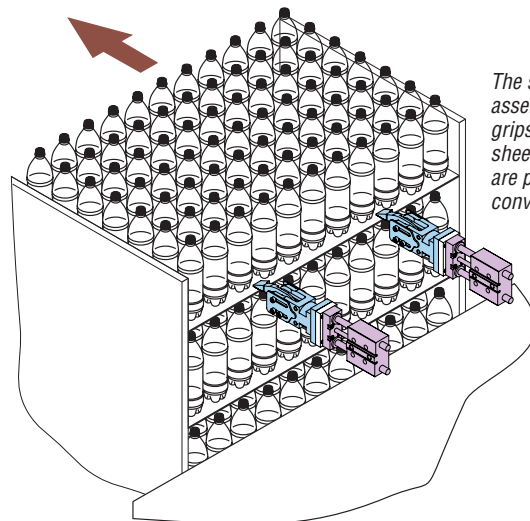

The slip sheet gripper assembly extends, grips and holds the sheet while the bottles are pushed onto a conveyor

PHD has developed many combinations of slip sheet grippers based on application requirements.

ML NUMBER	CLAMP	SLIDE	STROKE
314235	GRM2TN-2-30-30	SBH114x3-AE	3 in
310760	GRM2TS-2-30SDB-30SDB	SBH114x3-AE	3 in
310000	GRM2TN-2-15-15 (C4323)	SBL120x1	1 in
309533	GRM2TN-6-22-22	SBL520x25-J3	25 mm
307794	GRM2TN-2-22-22	SBL120x1	1 in
310477	GRM2TN-2-75-75	SBL120-2	2 in
310412	GRM2TN-2-22-22	SBH120x2-AE	2 in
310136	GRM2TN-2-22-22	SBL120x2	2 in
310570	GRM2TH-2-15SDB-00 (C5034)	ML310567 (SBL120x2 side ported)	2 in
310660	GRM2TN-2-22-22	SBL120x2	2 in
309940	GRM2TN-2-22-22	SBL120x3	3 in
309126	GRM2TN-2-22	SBL120x3-AE	3 in
309841	GRM2TN-6-22-22	ML309843 (SBH520x100)	100 mm
309419	GRM2TN-2-22-22	SBH125x1	1 in
309260	GRM2TN-2-22-22	SBH132x6	6 in

Jaws can be specified with urethane coating.

All dimensions are reference only unless specifically toleranced.

DIMENSIONS: SLIP SHEET GRIPPER ASSEMBLY

ML310760 (with Series GRM1 Clamp)

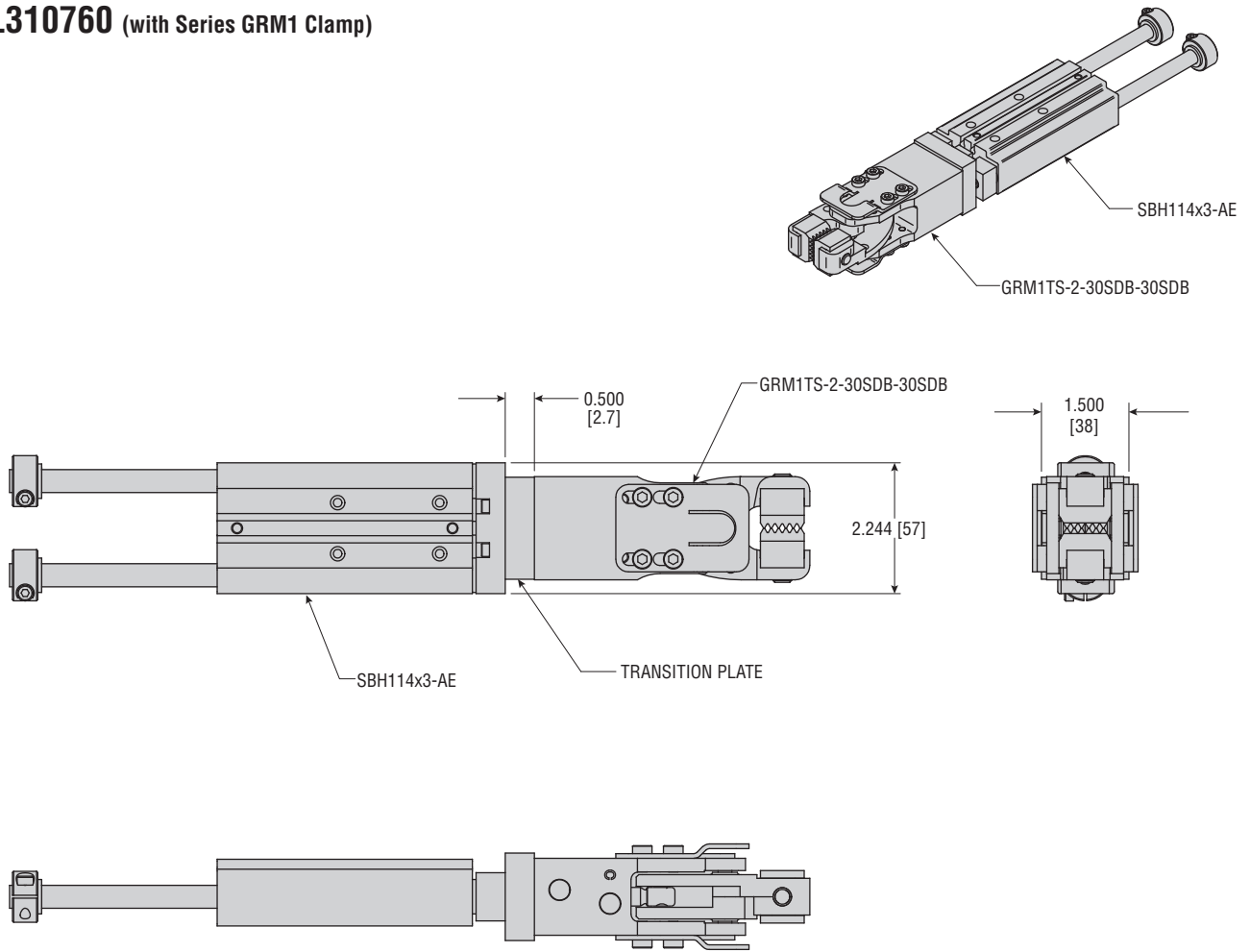

All dimensions are reference only unless specifically toleranced.

DIMENSIONS: SLIP SHEET GRIPPER ASSEMBLY

ML314235 (with Series GRM1 Clamp)

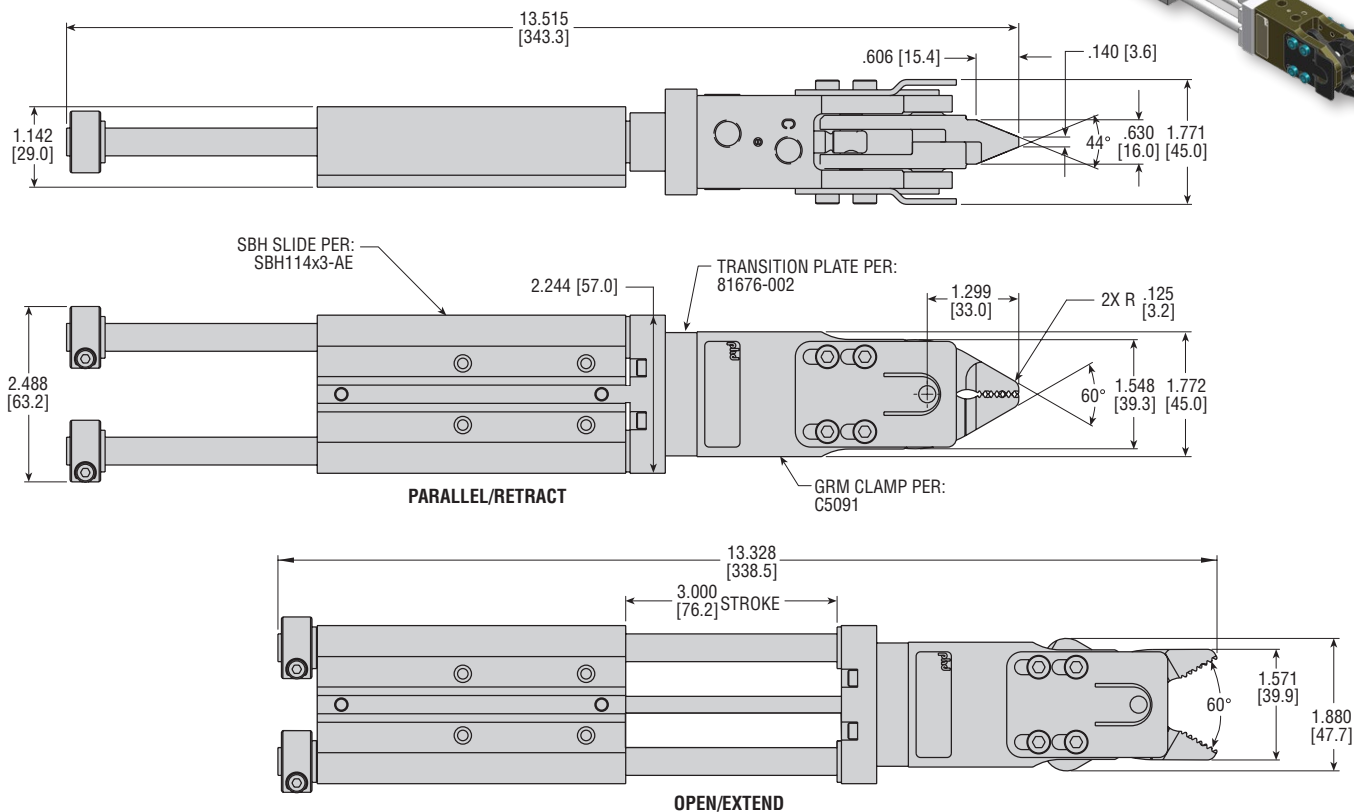

ML307794 (with Series GRM2 Clamp)

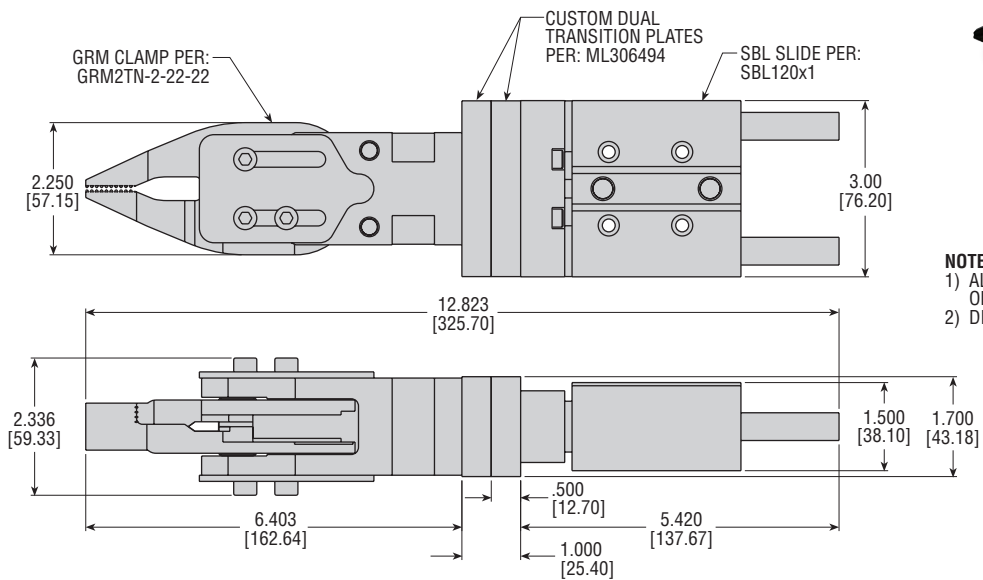

- NOTES:**
 1) ALL DIMENSIONS ARE FOR REFERENCE ONLY UNLESS SPECIFICALLY TOLERANCED.
 2) DIMENSIONS IN [] ARE mm.

All dimensions are reference only unless specifically toleranced.

Machine Lift Cylinder

ML314023 - 'K' Style spare component

MAJOR BENEFITS

- Used on 'K' style volumetric filler machines
- Direct replacement for the previous OEM-supplied Norgren SPC/050198/25
- 40 mm bore x 25 mm stroke
- Food grade seals
- Stainless construction
- Tested for millions of cycles
- Hygienic design for washdown

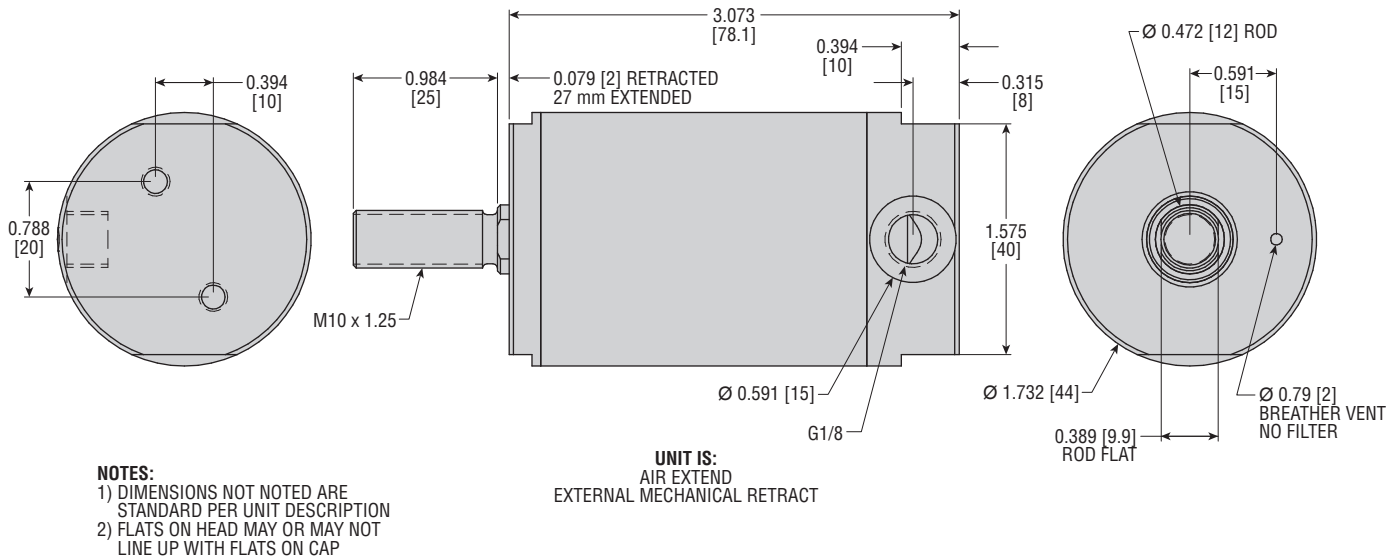
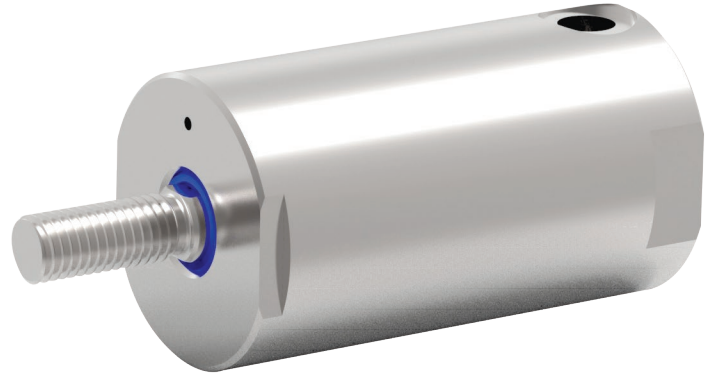

All dimensions are reference only unless specifically toleranced.

2 Position Filler Cylinder

ML312828 - 'K' Style 55 mm Bolt Spacing
 ML313378 - 'K' Style 60 mm Bolt Spacing

MAJOR BENEFITS

- Reliable, field-tested design provides consistent performance
- Replaces failure-prone diaphragm with simple piston design for superior operation
- Round design more hygienic/cleaner, for easy washdown
- Passivated stainless steel for food and beverage industry
- Spare component for certain 'K' Style filler valves requires no modifications to implement this product
- Lubricant free
- Food grade seals

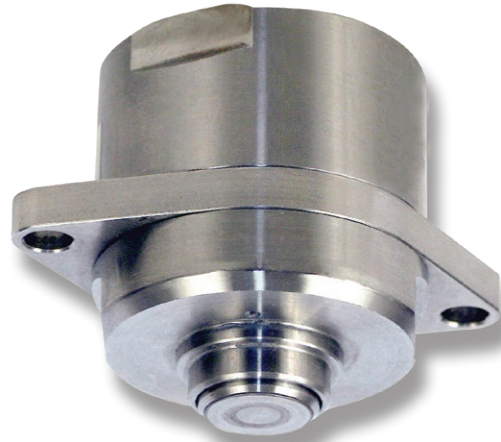

ML312828 - 55 mm Bolt Spacing

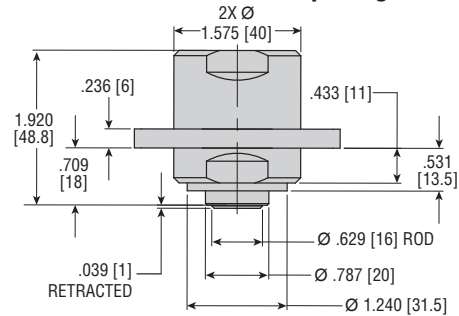

SPECIFICATIONS	ML312828	ML313378
STROKE	0.414 in [10.5]	0.430 in [10.9]
BORE	1 in [25.4]	1-1/4 in [31.8]
COMPONENTS	300 Series Stainless Steel	300 Series Stainless Steel
PISTON SEAL	Fluoroelastomer	Fluoroelastomer
BUSHING	Composite	Composite
CAP SEAL	PTFE	PTFE

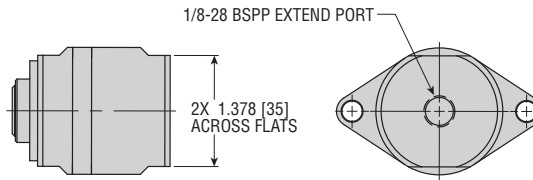
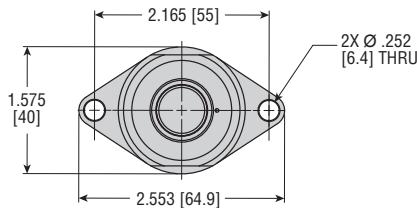

- NOTES:**
- 1) DIMENSIONS IN [] ARE mm
 - 2) UNIT FEATURES:
 - 1.000 [25.4] BORE
 - STROKE = 0.414 ±0.020 [10.5 ±0.5]
 - 3) THIS UNIT USES NO LUBRICATION

ML313378 - 60 mm Bolt Spacing

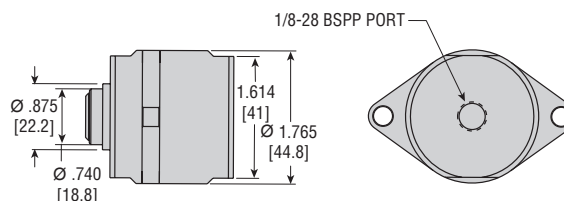
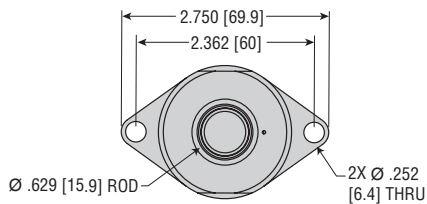
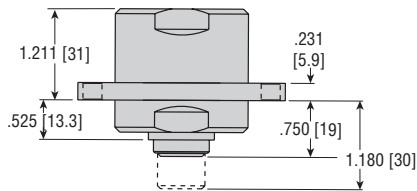

- NOTES:**
- 1) DIMENSIONS IN [] ARE mm
 - 2) UNIT FEATURES:
 - 1.000 [25.4] BORE
 - STROKE = 0.414 ±0.020 [10.5 ±0.5]
 - 3) THIS UNIT USES NO LUBRICATION

All dimensions are reference only unless specifically toleranced.

Series FCB Filler Cylinder

ML314051 - 'K' Style 45 40152 and 45 40156

ML314569 - 'K' Style 45 40150

ML314570 - 'K' Style 45 40155 and 45 40153

MAJOR BENEFITS

- Reliable, field-tested design provides consistent performance
- Replaces failure-prone diaphragm with simple piston design for superior operation
- Round design more hygienic/cleaner, for easy washdown
- Passivated stainless steel for food and beverage industry
- Spare component for certain 'K' Style filler valves requires no modifications to implement this product
- ML314051 and 314569 are lubricant free
- Food grade seals
- Reduced air volume for additional savings



Full Retract

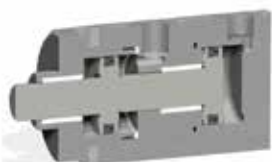

Mid Position



Full Extend

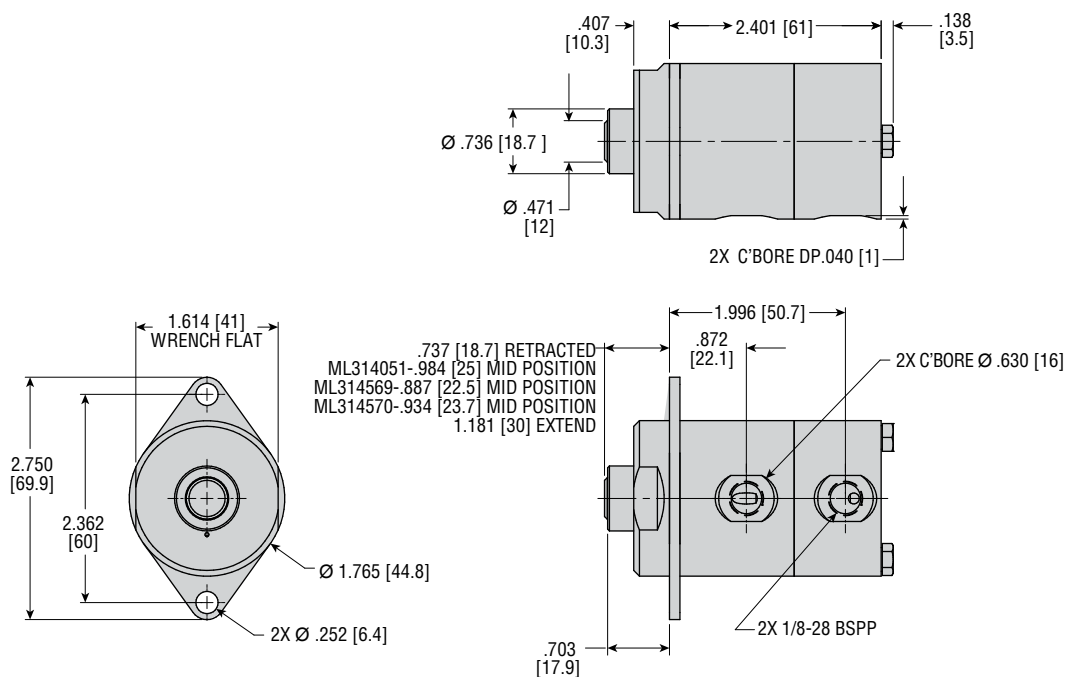

All dimensions are reference only unless specifically toleranced.

Volumetric Pump

ML302807

MAJOR BENEFITS

- 303 Stainless steel body, piston rod, adjustment screws, sand fasteners
- Adjustable screw for volume adjustment
- Additional Buna-N quad seal for added sealing and protection
- Compact design
- Many other volumes and configurations available. Contact PHD for more information.



SPECIFICATIONS	VOLUMETRIC PUMP
UNIT WEIGHT	1 lb [454 g]
BORE SIZE	1 in [25.4 mm]
MINIMUM AIR PRESSURE	10 psi [0.7 bar]
MAXIMUM AIR PRESSURE	150 psi [10.3 bar]
TOTAL STROKE	.66 in [16.8 mm]
MAX. OPERATING TEMPERATURE	200°F [93°C]
DISPLACEMENT (AIR)	.553 in ³ [9.06 mL]
DISPLACEMENT (PUMP)	.292 in ³ [4.785 mL]

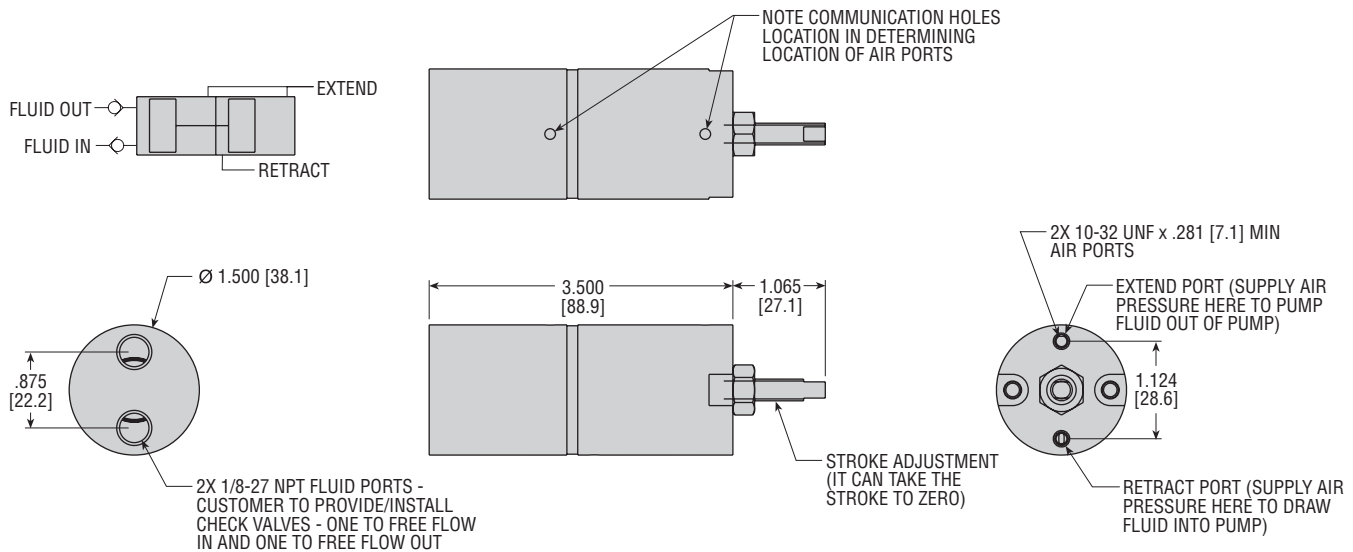

NOTE: ALL METRIC DIMENSIONS ARE GIVEN IN MILLIMETERS 1 mm = .03937 in

All dimensions are reference only unless specifically toleranced.

Cam Follower Wheels

MAJOR BENEFITS

- Provides longer life than OEM product (up to 8 times in some instances)
- Competitive price point
- Can be produced in several materials to fit specific application requirements
- Can be produced in any size to fit a machine
- Can be designed for cappers, fillers, etc.
- Global availability and support



APPLICATION

On rotary machines, cams are used to drive containers, fill heads, and capping heads into position. Cam follower wheels roll on the cams to actuate the different processes.



Eject Slide

ML309590

Can be used to replace units provided by TapTone®, Filtec®, and others

MAJOR BENEFITS

- Provides rapid repeatable ejection function due to MAC valve design and PHD cylinder.
- High kinetic energy capacity
- Eject slide uses proven PHD thruster slide technology
- Provides faster delivery times than OEM product
- In many cases lower cost solution than OEM product
- Intended for high speed part rejection
- Other sizes available to meet application requirements

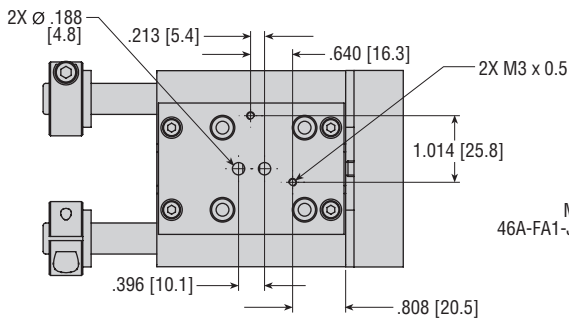
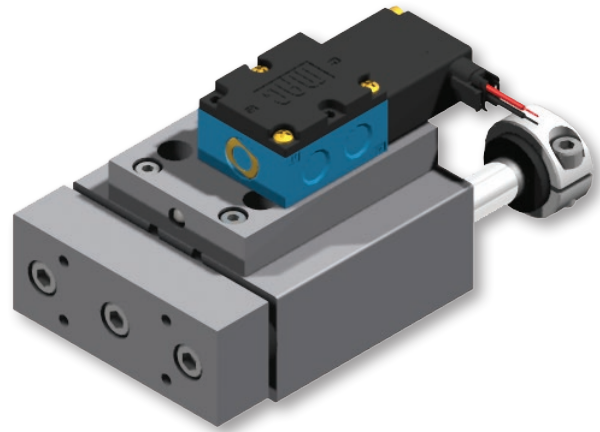

VIEW A-A
MAC VALVE INTERFACE

NOTES:
1) MAC VALVE SHOWN FOR REFERENCE ONLY, DISTRIBUTOR TO SUPPLY AND INSTALL
2) MOUNT SLIDE USING THRU AND C'BORES, SLIDE MUST BE MOUNTED PRIOR TO INSTALLING VALVE

MAC VALVE PER
46A-FA1-JAA0-1KA=532S

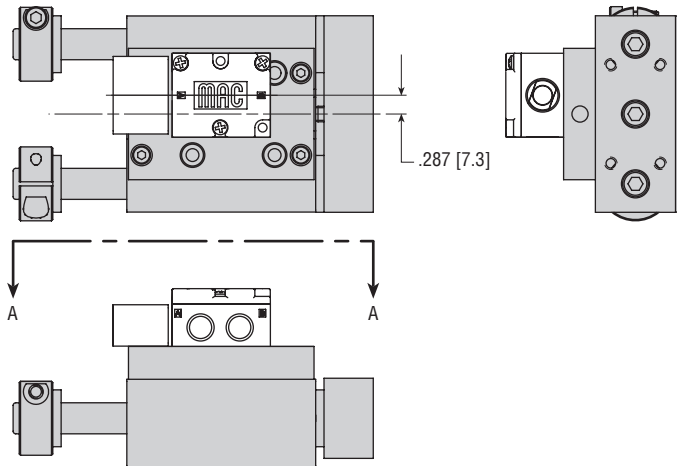
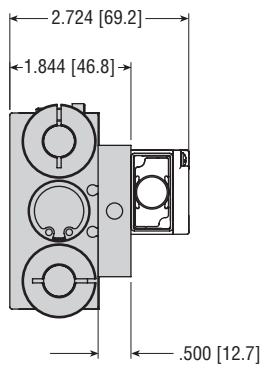
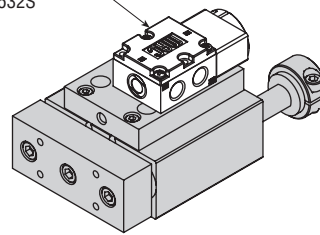

All dimensions are reference only unless specifically toleranced.

Overhead Case Turner

MAJOR BENEFITS

- Bolt-in replacement slide design
- PHD slides are field repairable, saving the customer additional cost.
- Standard SD/SE delivery times of one to four days
- Standard repair parts available
- Longer life than OEM product

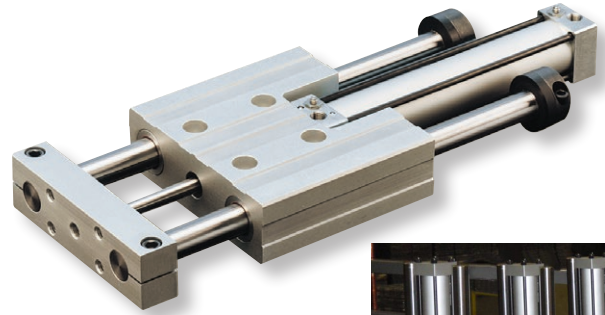

Side Case Turner

Replacement for High Speed Case Palletizer
CVAS2V32x3-DB-TEE

MAJOR BENEFITS

- More robust pillow block mounting provides stronger pivot point.
- Spherical bearing allows for misalignment for increased durability.
- ISO/VDMA interchange for easy mounting (metric unit)
- Imperial unit provides simplified integration in imperial facilities.
- PTFE wear ring provides piston support and enhances durability.
- Built-in shock pads are standard, absorbing impact energy and eliminating metal to metal contact
- Increased piston seal retention for higher speed applications
- Cylinders, including port and cushion controls, are easily repairable, maximizing your investment.

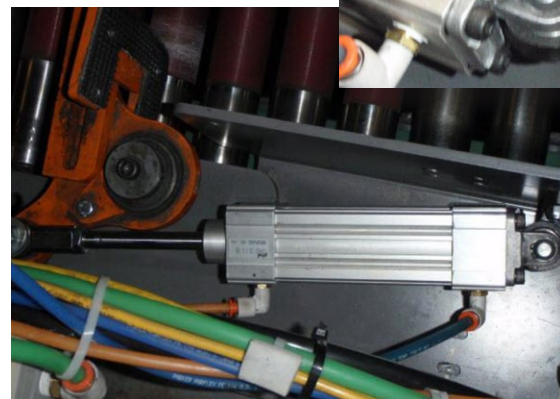

Rebuild Program

REBUILD REPAIR RECYCLE

Return your old units for rebuilding



Get a 12 Month
"Like New"
Warranty

Plastic Packaging Components such as Stretching Cylinders, Transfer Arms, Blow Nozzles, Filler Cylinders, Slip Sheet Grippers, and Eject Slides are rebuildable.

REBUILD IT YOURSELF OR ALLOW PHD?

PHD's rebuild program can save your facility training, additional work load, possible tool requirements, and facility space to perform the rebuilds. In addition, you will receive a 12 month "like new" warranty.

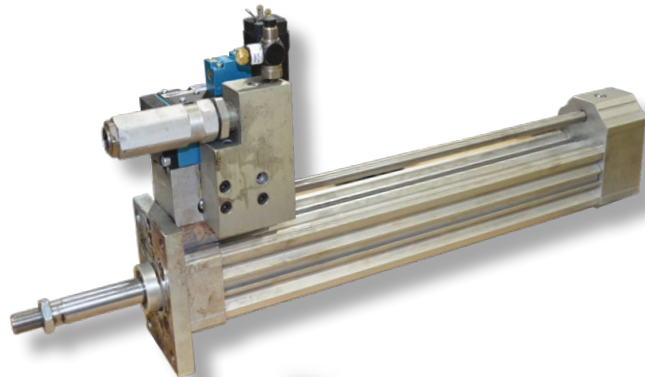

Before:

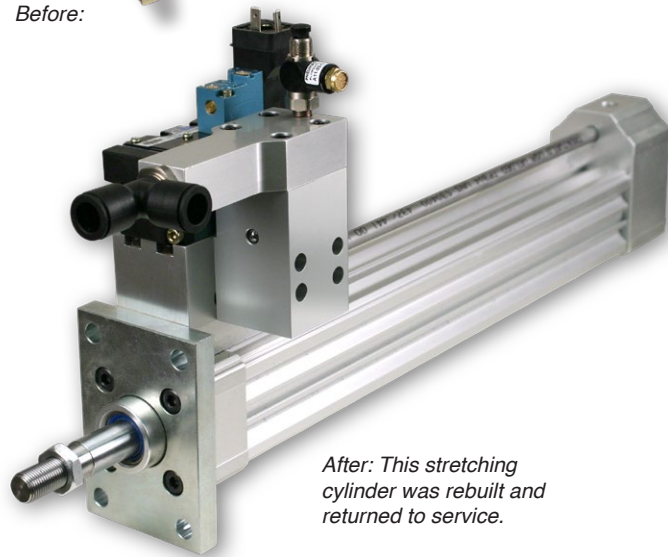

After: This stretching cylinder was rebuilt and returned to service.

- ➔ PHD's Rebuild Program refurbishes your existing PHD products with all new wear items.
- ➔ Rebuilt units offer the same PHD quality that you're used to, but for a fraction of the cost of a new unit, reducing your total cost of ownership.
- ➔ Rebuilt units are placed back into service, thus reducing your total cost and saving valuable components from scrap.
- ➔ All PHD factory rebuilt units receive a 12 month "like new" warranty.

UNIQUE SOLUTIONS® SPECIAL REQUIREMENTS

MADE SIMPLE



PHD Unlimited Unique Solutions® designs and manufactures units to meet the special requirements of our customers. We welcome and encourage requests for specialized products, regardless of quantity or frequency of order. Our solutions range from one-time-only units to high quantity requirements. With over 30,000 designs and over 100,000 quotes already in our database, we can provide most quotes within eight working hours. When it comes to delivery, PHD is the best. Give us a call or go online and see how we can become your engineering partner.

Capabilities

- Most quotes delivered within eight working hours
- Dedicated application assistance
- 24 hours a day, 7 days a week service
- Fast delivery and competitive pricing
- Separate unique solutions engineering and manufacturing areas dedicated to our customers, ensuring prompt quotes and dependable delivery
- Over 30,000 unique solutions provided and over 100,000 quotes in our database

Quotes Online

- Available 24 hours a day, 7 days a week
- Enter and edit order prior to contact information
- Submit your quote and an MDN representative will contact you with a quote
- No minimum quantities are required
- CAD files available prior to ordering
- Geared towards short-run requests
- All units receive an "ML" number when ordered. This number, along with all specifications, is kept on permanent record at PHD for future reference and reorders.

www.phdinc.com/unlimited/quote

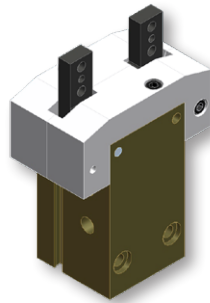

Angular Bottle Gripper ML313267

- Drop-in Festo replacement
- Longer life than OEM product
- Does not damage bottle preforms
- Minimal jaw play
- Switch slots offer flush mounting
- Dowel holes on hardened steel jaws offer precise tooling location
- Hardcoated aluminum body

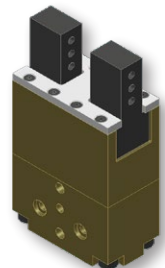

Parallel Preform Gripper ML312135

- Drop-in Festo replacement
- Longer life than OEM product
- Does not damage bottle preforms
- Minimal jaw play
- Switch slots offer flush mounting
- Dowel holes on hardened steel jaws offer precise tooling location
- Hardcoated aluminum body



Filler Cylinder Can/Football Styles

- Drop-in component for 'K' Style filler valves - Requires no modification to implement
- Long life
- Easy rebuild
- Available with or without non-rotating feature
- Reliable, field-tested design provides consistent performance, reducing under and over fills



To request a free brochure, visit www.phdinc.com/resources/infrequest/

OTHER SOLUTIONS

'S' STYLE

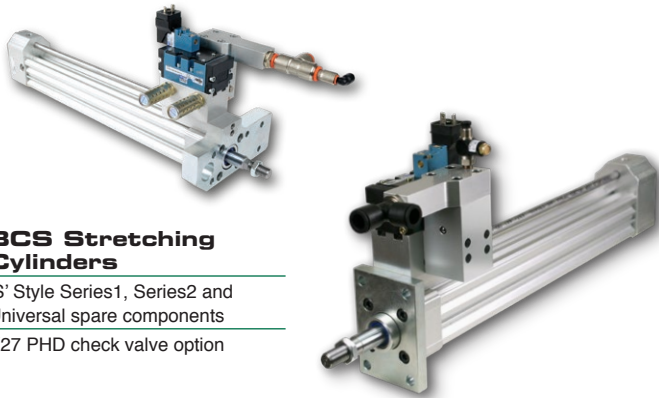

BCS Stretching Cylinders

'S' Style Series1, Series2 and Universal spare components
X27 PHD check valve option



BCZ Nozzle Cylinders

'S' Style Series2 and Universal spare components
Valve manifold assembled to cylinder available as standard

BST1 Transfer Arm

'S' Style Series1 spare component
Significantly more robust and precise than other transfer arms
Designed to operate over 20 million cycles

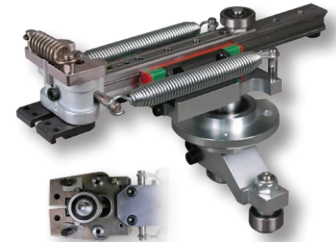

BST Transfer Arm Preferential Head

BST2 Transfer Arm

'S' Style Series2 spare component
Vertical height adjustment eliminates need for shims
Designed to operate over 20 million cycles



Preform/ Bottle Eject Slide

'S' Style Series2 spare component
Consistent preform/bottle ejection
Minimizes stress on transfer arm jaws

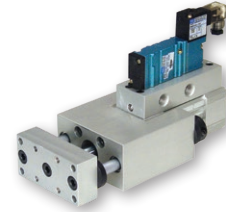

'K' STYLE

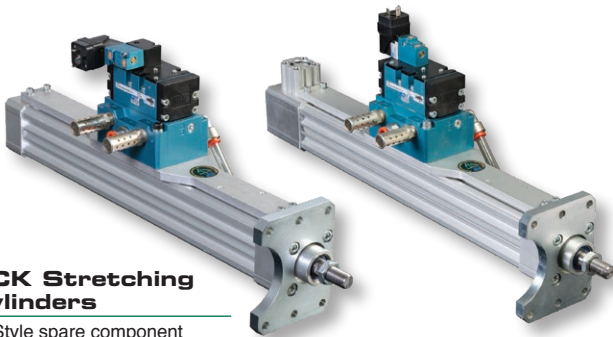

BCK Stretching Cylinders

'K' Style spare component
Simplified pneumatic system

Transfer Arm Head

ML311628

'K' Style spare component



To request more literature, visit www.phdinc.com/resources/inforequest/

Eject Cylinders

ML309880 and ML310656

'K' Style spare component
Provides rapid repeatable ejection function due to MAC valve design and PHD cylinder.

High kinetic energy capacity
Provides faster delivery times than OEM product

In many cases lower cost solution than OEM product

Intended for high speed part rejection

