



PNEUMATIC COMPACT CYLINDER

Major Benefits

- Compact design for applications where space is limited
- Up to six switch slots for flush switch mounting
- Self-lubricating nitrile piston seal for long cylinder life
- Multiple mounting options



CRS

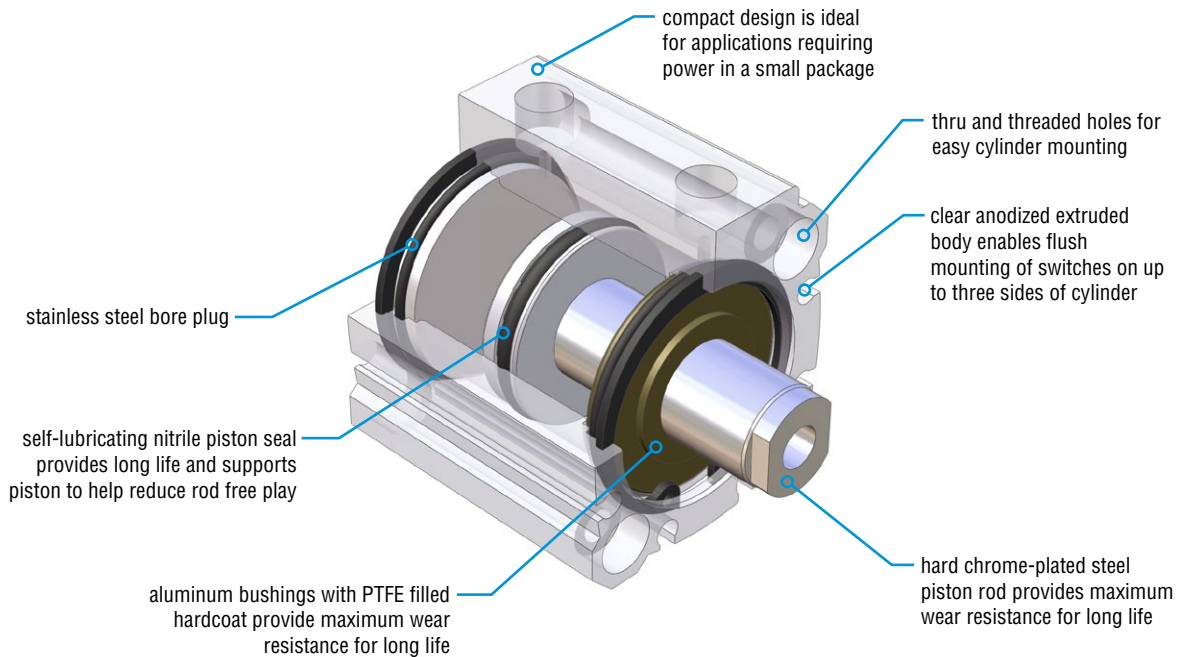

BEST PRACTICES FOR MAXIMUM CYLINDER LIFE

Shown below are the best ways to apply PHD Series CRS Cylinders. The key to proper application and long cylinder life is using the cylinder to provide power and motion while externally stopping any attached loads.

APPLICATION #1 - ATTACHED LOAD

Loads connected to the cylinder rod must always be stopped externally. Strokes, rod lengths, and attached loads should be designed so that the piston never impacts the head or cap. For vertical applications only.

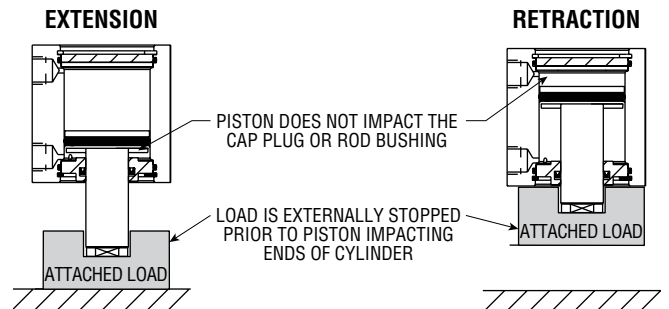

ORDERING DATA: SERIES CRS COMPACT CYLINDERS

CRS

TO ORDER SPECIFY:

Product, Series, Type, Design No.,
Mounting Style, Bore Size, Stroke, and Options.

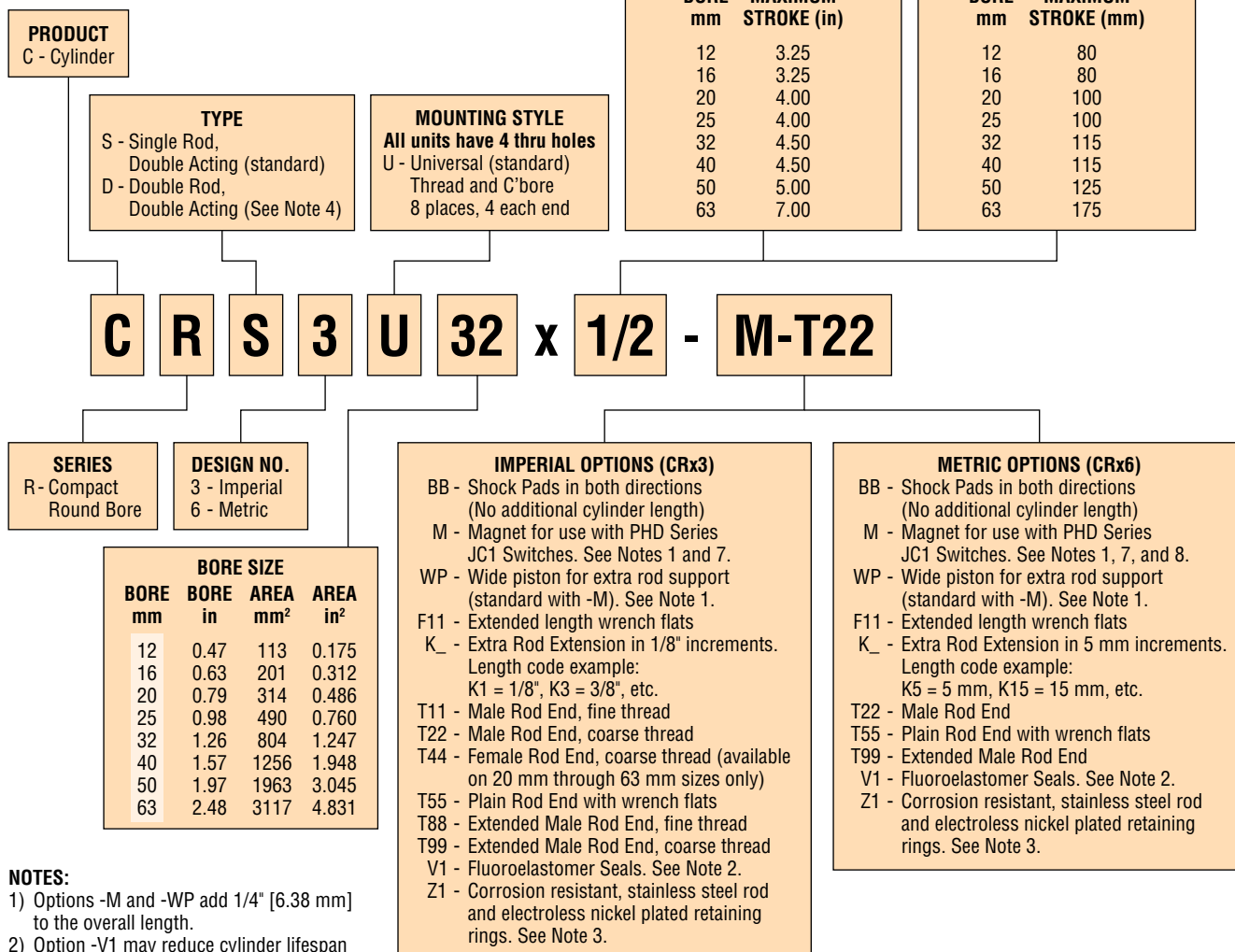

NOTES:

- Options -M and -WP add 1/4" [6.38 mm] to the overall length.
- Option -V1 may reduce cylinder lifespan due to fluorocarbon seal material.
- Option -Z1 may reduce cylinder lifespan due to stainless steel rod in place of chrome plated steel.
- Double rod units' rear rod will receive same rod option as single rod.
- For longer stroke lengths available, consult PHD.
- See pages 1-13 through 1-16 for accessories.
- PHD recommends the use of stainless steel or de-magnetized fasteners on units with the -M option.
- See options pages for switch ordering information.

Options may affect unit length. See dimensional pages and option information details.

JC1 SOLID STATE AND REED SWITCHES

| JC1 SWITCH | DESCRIPTION |
|------------|-----------------------------------|
| JC1SDN-5 | NPN DC Solid State, 5 meter cable |
| JC1SDP-5 | PNP DC Solid State, 5 meter cable |
| JC1SDN-K | NPN DC Solid State, Quick Connect |
| JC1SDP-K | PNP DC Solid State, Quick Connect |
| JC1RDU-5 | PNP or NPN DC Reed, 5 meter cable |
| JC1RDU-K | PNP or NPN DC Reed, Quick Connect |
| JC1ADU-K | AC Reed, Quick Connect |

NOTE: See Switches and Sensors section for additional switch information and complete specification. Switches must be ordered separately.

JC1 SOLID STATE AND REED CORDSETS

| PART NO. | DESCRIPTION |
|-------------|--|
| 63549-02 | M8, 3 pin, Straight Female Connector, 2 meter cable |
| 63549-05 | M8, 3 pin, Straight Female Connector, 5 meter cable |
| 81284-1-010 | M12, 3 pin, Straight Female Connector, 2 meter cable |

NOTE: Cordsets are ordered separately.



CAD & Sizing Assistance

Use PHD's free online Product Sizing and CAD Configurator at www.phdinc.com/myphd

ENGINEERING DATA: SERIES CRS COMPACT CYLINDERS

| SPECIFICATIONS | SERIES CRS |
|--------------------|--|
| OPERATING PRESSURE | 10 psi min to 150 psi max at zero load [0.7 bar min to 10 bar max] air |
| STROKE TOLERANCE | ± 0.031 inch [± 0.8 mm] (See Shock Pad Usage) |
| TEMPERATURE LIMITS | -20° to +180°F [-29° to +82°C] |
| VELOCITY | 20 in/sec [0.5 m/sec] typical min, zero load at 100 psi [7 bar] |
| LIFE EXPECTANCY | 70 million linear inches [1.77 million linear meters] minimum at operating temperatures under 120°F [49°C] (-V1 & -Z1 options may reduce life) |
| LUBRICATION | Pre-lubricated for use with non-lubricated or lubricated air |
| MAINTENANCE | Field repairable |

CYLINDER FORCE AND WEIGHT

| BORE SIZE | | ROD DIAMETER | | ROD DIRECTION | EFFECTIVE AREA | | BASE WEIGHT | | ADDER PER 1" [25 mm] OF STROKE | |
|-----------|-------|--------------|-------|---------------|-----------------|-----------------|-------------|------|--------------------------------|------|
| mm | in | in | mm | | in ² | mm ² | lb | kg | lb | kg |
| 12 | 0.472 | 0.250 | 6.35 | EXTEND | 0.175 | 113 | 0.11 | 0.05 | 0.085 | 0.04 |
| | | | | RETRACT | 0.126 | 81 | | | | |
| 16 | 0.630 | 0.250 | 6.35 | EXTEND | 0.312 | 201 | 0.17 | 0.08 | 0.10 | 0.05 |
| | | | | RETRACT | 0.263 | 169 | | | | |
| 20 | 0.787 | 0.375 | 9.53 | EXTEND | 0.487 | 314 | 0.25 | 0.11 | 0.15 | 0.07 |
| | | | | RETRACT | 0.376 | 242 | | | | |
| 25 | 0.984 | 0.375 | 9.53 | EXTEND | 0.761 | 490 | 0.26 | 0.12 | 0.16 | 0.07 |
| | | | | RETRACT | 0.650 | 419 | | | | |
| 32 | 1.260 | 0.625 | 15.88 | EXTEND | 1.247 | 804 | 0.48 | 0.22 | 0.26 | 0.12 |
| | | | | RETRACT | 0.940 | 606 | | | | |
| 40 | 1.575 | 0.625 | 15.88 | EXTEND | 1.948 | 1256 | 0.60 | 0.27 | 0.30 | 0.14 |
| | | | | RETRACT | 1.641 | 1058 | | | | |
| 50 | 1.969 | 0.750 | 19.05 | EXTEND | 3.043 | 1963 | 0.78 | 0.35 | 0.40 | 0.18 |
| | | | | RETRACT | 2.602 | 1678 | | | | |
| 63 | 2.480 | 0.750 | 19.05 | EXTEND | 4.832 | 3117 | 0.95 | 0.43 | 0.48 | 0.22 |
| | | | | RETRACT | 4.390 | 2832 | | | | |

NOTE: Use retract figures for calculating double rod cylinder forces in both directions.

CYLINDER FORCE CALCULATIONS

| | Imperial | Metric |
|---|------------------|------------------------|
| | F = P x A | F = 0.1 x P x A |
| F = Cylinder Force | lbs | N |
| P = Operating Pressure | psi | bar |
| A = Effective Area (Extend or Retract) | in ² | mm ² |

APPLICATION

The PHD Series CRS Cylinders are designed for use as a source of power and motion. As with typical compact cylinders, the Series CRS Cylinder is not intended for applications where side loads or impact with attached loads are present. PHD recommends the use of external stops to ensure maximum cylinder life. See best application practices on page 1-5.

SHOCK PAD USAGE

Optional shock pads are recommended for applications where the piston travels the full stroke length and contacts the bushing and plug (with no attached loads). The use of shock pads reduces noise and provides maximum cylinder life in these applications. Stroke tolerance changes to ±0.050 [±1.3 mm] with -BB option.



Application & Sizing Assistance

Use PHD's free online Product Sizing Application at www.phdinc.com/apps/sizing

DIMENSIONS: SERIES CRS COMPACT CYLINDERS

12 mm and 16 mm BORE

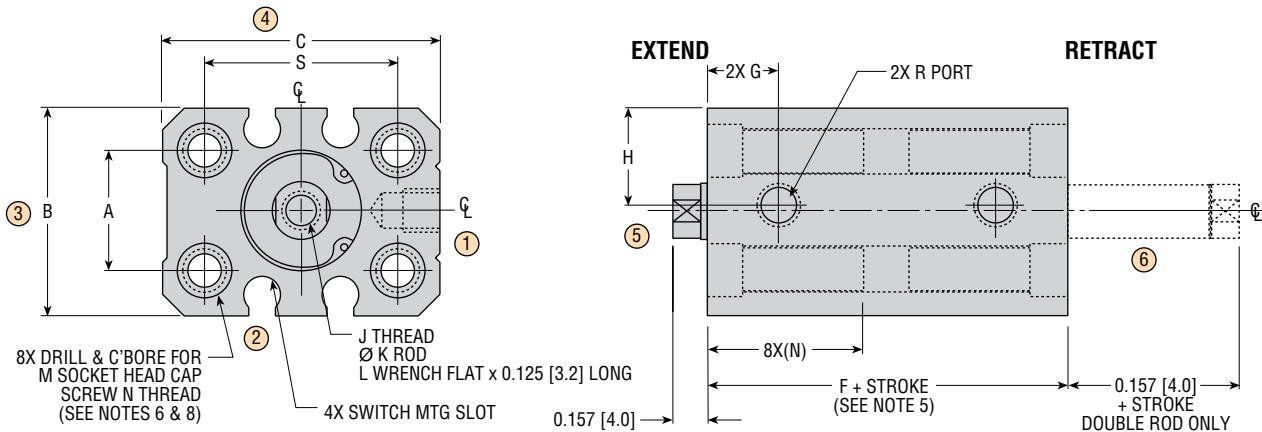

20 mm through 63 mm BORE

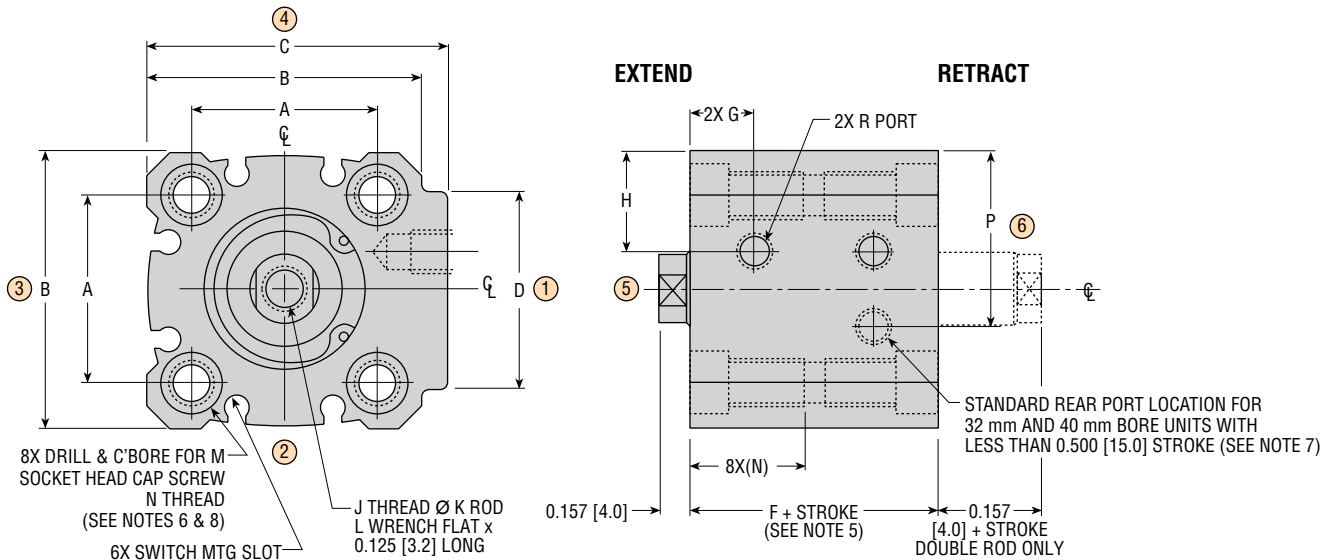

NOTES:

- 1) DIMENSIONS SHOWN IN [] ARE IN mm FOR METRIC UNITS [CRx6]
- 2) DESIGNATED CENTERLINE IS CENTERLINE OF CYLINDER BORE
- 3) UNLESS OTHERWISE DIMENSIONED, MOUNTING HOLE PATTERNS AND OTHER FEATURES ARE CENTERED ON DESIGNATED CYLINDER CENTERLINE
- 4) 1/4" [5 mm] MINIMUM STROKE REQUIRED
- 5) SEE DIMENSION CHART ON NEXT PAGE. DIMENSION F IS DIFFERENT FOR "PLAIN" UNIT AND WITH OPTIONS -M AND -WP.
- 6) C'BORE DEPTH OF MOUNTING HOLES MUST BE CONSIDERED TO DETERMINE PROPER MOUNTING FASTENER LENGTH
- 7) FOR 32 mm AND 40 mm BORE UNITS WITH STROKES LESS THAN 0.500" [15 mm], PHD RECOMMENDS THE USE OF FITTINGS WITH A HEX NO LARGER THAN 7/16" [13 mm] AND NOTE REAR PORT LOCATION CHANGE
- 8) PHD RECOMMENDS THE USE OF STAINLESS STEEL OR DE-MAGNETIZED FASTENERS ON UNITS WITH THE -M OPTION.



CAD & Sizing Assistance

Use PHD's free online Product Sizing and CAD Configurator at www.phdinc.com/myphd

All dimensions are reference only unless specifically toleranced.

DIMENSIONS: SERIES CRS COMPACT CYLINDERS

| BORE | LETTER DIMENSION | | | | | | | | | | | |
|---------------|------------------|-----------------|-----------------|-----------------|-----------------|------------------------|------------------|-----------------|-------------------------------------|------------------|-----------------|-------------|
| | A | B | C | D | F PLAIN | F WITH OPTIONS -M, -WP | G | H | J THREAD | K | L | M |
| 0.472 [12] | 0.550 [13.97] | 0.944 [24.0] | 1.260 [32.0] | — | 0.904 [23.0] | 1.154 [29.4] | 0.325 [8.26] | 0.472 [12.0] | 8-32 x 0.250 [M4 x 0.7 x 6] | 0.250 [6.35] | 0.219 [5.6] | #6 [M4] |
| 0.630 [16] | 0.710 [18.03] | 1.104 [28.0] | 1.340 [34.0] | — | 0.904 [23.0] | 1.154 [29.4] | 0.325 [8.26] | 0.454 [11.5] | 8-32 x 0.250 [M4 x 0.7 x 6] | 0.250 [6.35] | 0.219 [5.6] | #6 [M4] |
| 0.787 [20] | 1.000 [25.4] | 1.476 [37.5] | 1.576 [40.0] | 0.788 [20.0] | 0.920 [23.4] | 1.170 [29.7] | 0.350 [8.89] | 0.531 [13.5] | 1/4-28 x 0.375 [M6 x 1.0 x 9] | 0.375 [9.53] | 0.312 [7.9] | #10 [M5] |
| 0.984 [25] | 1.100 [28.0] | 1.576 [40.0] | 1.746 [44.4] | 1.000 [25.4] | 0.920 [23.4] | 1.170 [29.7] | 0.350 [8.89] | 0.552 [14.0] | 1/4-28 x 0.375 [M6 x 1.0 x 9] | 0.375 [9.53] | 0.312 [7.9] | #10 [M5] |
| 1.260 [32] | 1.339 [34.0] | 1.870 [47.5] | 2.037 [52.0] | 1.340 [34.0] | 1.022 [26.0] | 1.272 [32.3] | 0.375 [9.53] | 0.610 [15.5] | 5/16-24 x 0.470 [M8 x 1.25 x 11] | 0.625 [15.88] | 0.500 [12.7] | #10 [M5] |
| 1.575 [40] | 1.575 [40.0] | 2.205 [56.0] | 2.363 [60.0] | 1.420 [36.0] | 1.022 [26.0] | 1.272 [32.3] | 0.360 [9.14] | 0.738 [18.8] | 5/16-24 x 0.470 [M8 x 1.25 x 11] | 0.625 [15.88] | 0.500 [12.7] | #10 [M5] |
| 1.969 [50] | 1.969 [50.0] | 2.598 [66.0] | 2.795 [71.0] | 1.600 [40.6] | 1.300 [33.0] | 1.550 [39.4] | 0.472 [12.00] | 0.823 [21.0] | 3/8-24 x 0.563 [M10 x 1.5 x 13] | 0.750 [19.05] | 0.625 [15.9] | 1/4 [M6] |
| 2.480 [63] | 2.362 [60.0] | 3.070 [78.0] | 3.266 [83.0] | 2.094 [53.2] | 1.420 [36.0] | 1.670 [42.4] | 0.512 [13.00] | 0.865 [22.0] | 3/8-24 x 0.563 [M10 x 1.5 x 13] | 0.750 [19.05] | 0.625 [15.9] | 1/4 [M6] |

| BORE | LETTER DIMENSION | | | |
|---------------|---------------------------------------|-----------------|--------------------------------|-----------------|
| | N THREAD | P | R | S |
| 0.472 [12] | 10-24 x 0.550 [M5 x 0.8 x 14.5] | — | 10-32 x 0.15 [M5 x 0.8 x 4] | 0.866 [22.0] |
| 0.630 [16] | 10-24 x 0.550 [M5 x 0.8 x 14.5] | — | 10-32 x 0.15 [M5 x 0.8 x 4] | 0.946 [24.0] |
| 0.787 [20] | 1/4-20 x 0.875 [M6 x 1.0 x 22.5] | — | 10-32 x 0.15 [M5 x 0.8 x 4] | — |
| 0.984 [25] | 1/4-20 x 0.875 [M6 x 1.0 x 22.5] | — | 10-32 x 0.15 [M5 x 0.8 x 4] | — |
| 1.260 [32] | 1/4-20 x 0.875 [M6 x 1.0 x 22.5] | 0.900 [22.9] | 1/8 NPT [1/8 BSP] | — |
| 1.575 [40] | 1/4-20 x 0.875 [M6 x 1.0 x 22.5] | 1.072 [27.2] | 1/8 NPT [1/8 BSP] | — |
| 1.969 [50] | 5/16-18 x 0.900 [M8 x 1.25 x 22.5] | — | 1/8 NPT [1/8 BSP] | — |
| 2.480 [63] | 5/16-18 x 0.900 [M8 x 1.25 x 22.5] | — | 1/4 NPT [1/4 BSP] | — |

Numbers in [] are in mm for metric units [CRx6].



CAD & Sizing Assistance

Use PHD's free online Product Sizing and CAD Configurator at www.phdinc.com/myphd

All dimensions are reference only unless specifically toleranced.

OPTIONS: SERIES CRS COMPACT CYLINDERS

CRS

BB

SHOCK PADS ON EXTENSION AND RETRACTION

Shock pads eliminate metal-to-metal contact and minimize piston impact. Shock pads are recommended for applications where the piston travels the full stroke length and contacts the head and/or cap (with no attached loads). The use of shock pads reduces noise and provides maximum cylinder life in these applications.

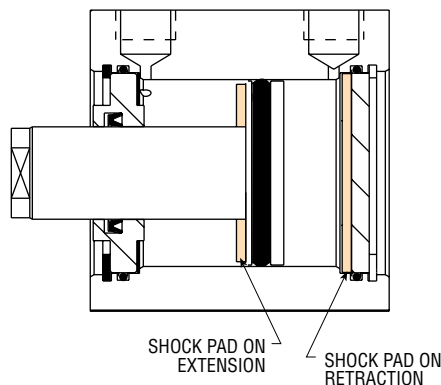

F11

EXTENDED LENGTH WRENCH FLATS

The design of a compact cylinder requires the length to be as short as possible. The standard wrench flat length is 0.125" [3 mm]. The option -F11 provides wrench flats which allow standard wrench access.

| BORE [mm] | A EXTENDED WRENCH FLATS | | B ROD EXTENSION | |
|-----------|-------------------------|--------|-----------------|-------|
| 12/16 | 0.200 | [5.08] | 0.250 | [6.5] |
| 20/25 | 0.200 | [5.08] | 0.250 | [6.5] |
| 32/40 | 0.290 | [8.00] | 0.344 | [9.0] |
| 50/63 | 0.290 | [8.00] | 0.344 | [9.0] |

Numbers in [] are in mm for metric units [CRx6].

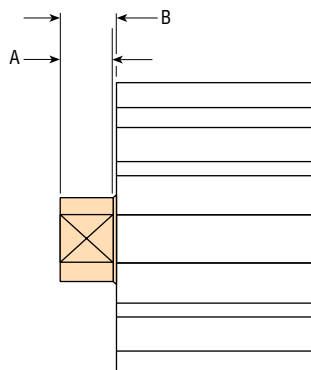

K_

EXTRA ROD EXTENSION

Extra rod extension can be achieved by specifying the option -K followed by the length code.

Length code example (for imperial CRx3 units)

K1 = 1/8" of extra rod extension

K3 = 3/8", etc.

Length code example (for metric CRx6 units)

K5 = 5 mm of extra rod extension

K15 = 15 mm, etc.

0.157" [4 mm] of rod extension is standard. Available in 1/8" [5 mm] increments only.

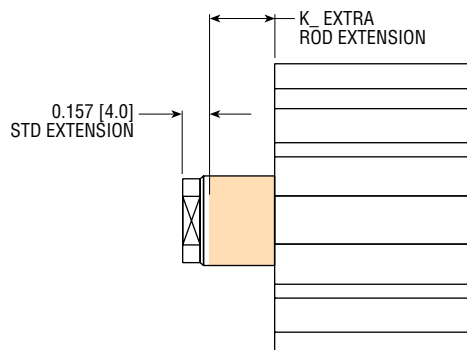

All dimensions are reference only unless specifically tolerated.

OPTIONS: SERIES CRS COMPACT CYLINDERS

M

MAGNET FOR PHD SERIES JC1 SWITCHES

This option equips the cylinder with a magnetic band on the piston for use with PHD Series JC1 Switches. These switches mount easily into the integral slots in the body. **Hand tighten the setscrew until the switch is securely retained. Do not overtighten.** PHD recommends the use of stainless steel or de-magnetized fasteners on units with this option.

NOTE: Option -M adds 0.250 in [6.38 mm] to the overall length of the cylinder of a plain unit.

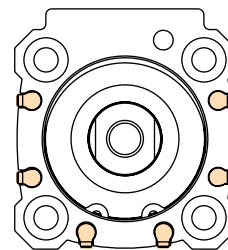

CRS

JC1 SOLID STATE AND REED SWITCHES

| JC1 SWITCH | DESCRIPTION |
|------------|-----------------------------------|
| JC1SDN-5 | NPN DC Solid State, 5 meter cable |
| JC1SDP-5 | PNP DC Solid State, 5 meter cable |
| JC1SDN-K | NPN DC Solid State, Quick Connect |
| JC1SDP-K | PNP DC Solid State, Quick Connect |
| JC1RDU-5 | PNP or NPN DC Reed, 5 meter cable |
| JC1RDU-K | PNP or NPN DC Reed, Quick Connect |
| JC1ADU-K | AC Reed, Quick Connect |

NOTE: See Switches and Sensors section for additional switch information and complete specification. Switches must be ordered separately.

JC1 SOLID STATE AND REED CORDSETS

| PART NO. | DESCRIPTION |
|-------------|--|
| 63549-02 | M8, 3 pin, Straight Female Connector, 2 meter cable |
| 63549-05 | M8, 3 pin, Straight Female Connector, 5 meter cable |
| 81284-1-010 | M12, 3 pin, Straight Female Connector, 2 meter cable |

NOTE: Cordsets are ordered separately.

WP

WIDE PISTON FOR EXTRA ROD END SUPPORT

This option provides additional rod end stability. All units with magnetic pistons will automatically receive a wide piston to accommodate the magnet.

NOTE: Option -WP, adds 0.250 in [6.38 mm] to the overall length of the cylinder of a plain unit.

V1

FLUOROELASTOMER SEALS

Fluoroelastomer seals are compatible with certain fluids which degrade standard Nitrile seals. Seal compatibility should be checked with the fluid manufacturer for correct application. Consult PHD for high temperature use.

OPTIONS: SERIES CRS COMPACT CYLINDERS

CRS

T11 MALE ROD END, FINE THREAD (Not available on CRx6 units)

T22 MALE ROD END, COARSE THREAD

These options provide a studded male rod end in place of the standard female threaded rod end. The metric CRS is available with coarse threads only. See pages 1-8 and 1-9 for specifications of standard rod ends.

| BORE [mm] | -T11 FINE | -T22 COARSE | | B | |
|-----------|-----------|-------------|-------------|-------|--------|
| | A THREAD | A THREAD | A THREAD | | |
| 12/16 | N/A | 8-32 | [M4 x 0.7] | 0.325 | [8.5] |
| 20/25 | 1/4-28 | 1/4-20 | [M6 x 1.0] | 0.580 | [14.9] |
| 32/40 | 5/16-24 | 5/16-18 | [M8 x 1.25] | 0.625 | [17.5] |
| 50/63 | 3/8-24 | 3/8-16 | [M10 x 1.5] | 0.810 | [20.5] |

NOTES:

- 1) Numbers in [] are in mm for metric units [CRx6].
- 2) On double rod units, rear rod receives same rod end as single rod.

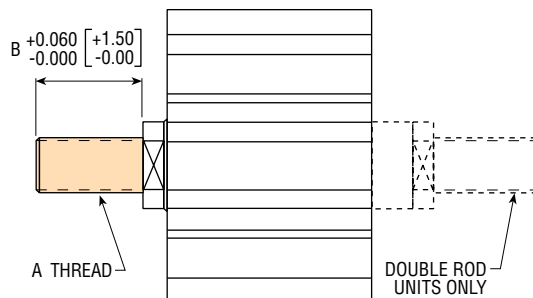

T44 FEMALE ROD END, COARSE THREAD (CRx3 20-63 units only)

This option provides a female coarse thread rod end. This option can be applied to imperial 20 mm through 63 mm bore units. The imperial 12 mm and 16 mm bore units have an 8-32 coarse thread as standard. See pages 1-8 and 1-9 for standard thread sizes. The metric 12 mm through 63 mm bore units have coarse threads as standard.

| BORE [mm] | -T44 COARSE | | | |
|-----------|-------------|----------|----------|-------|
| | A THREAD | A THREAD | A THREAD | B |
| 12/16 | (STD) | (STD) | (STD) | (STD) |
| 20/25 | 1/4-20 | (STD) | 0.375 | (STD) |
| 32/40 | 5/16-18 | (STD) | 0.470 | (STD) |
| 50/63 | 3/8-16 | (STD) | 0.562 | (STD) |

NOTE: On double rod units, rear rod receives same rod end as single rod.

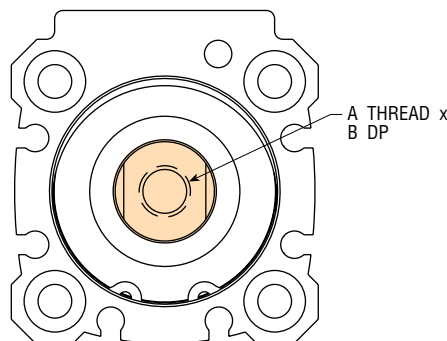

T55 PLAIN ROD END

This option provides a plain rod end with wrench flats. Standard PHD Compact Cylinders are supplied with a female rod end.

NOTE: On double rod units, rear rod receives same rod end as single rod.

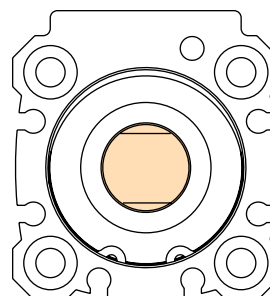

All dimensions are reference only unless specifically toleranced.

OPTIONS: SERIES CRS COMPACT CYLINDERS

T88 EXTENDED MALE ROD END, FINE THREAD
(Not available on CRx6 units)

T99 EXTENDED MALE ROD END, COARSE THREAD

These options provide a studed male rod end with extended length threads. Metric CRS units are available with coarse threads only. See previous page for standard length male rod end options.

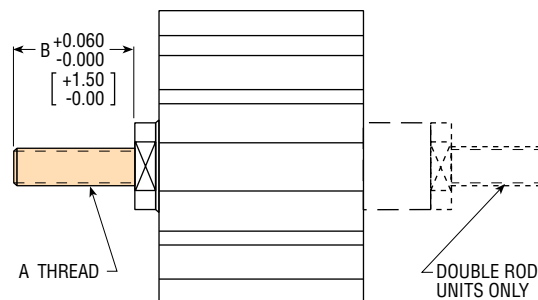

| BORE [mm] | -T88 FINE A THREAD | -T99 COARSE A THREAD | B | |
|-----------|--------------------|----------------------|-------------|--------------|
| 12/16 | N/A | 8-32 | [M4 x 0.7] | 0.700 [17.5] |
| 20/25 | 1/4-28 | 1/4-20 | [M6 x 1.0] | 1.200 [29.5] |
| 32/40 | 5/16-24 | 5/16-18 | [M8 x 1.25] | 1.250 [32.5] |
| 50/63 | 3/8-24 | 3/8-16 | [M10 x 1.5] | 1.690 [35.5] |

NOTES:

- 1) Numbers in [] are in mm for metric units [CRx6].
- 2) On double rod units, rear rod receives same rod end as single rod.

Z1 CORROSION RESISTANT

Electroless nickel plating is applied to the retaining rings and a stainless steel piston rod is supplied. Male rod ends are not plated when this option is specified. This option may reduce seal life.

ACCESSORIES: SERIES CRS COMPACT CYLINDERS

HEXAGONAL NUT KIT

Nut kits include a hexagonal nut for use with male studed rod ends. All male rod end options are shipped without hexagonal nuts.

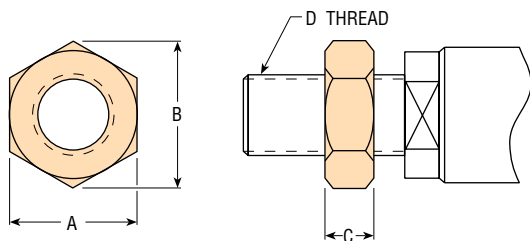

| BORE [mm] | DIMENSIONS | | | D THREAD FINE | KIT NO. | D THREAD COARSE | KIT NO. COARSE |
|-----------|--------------|--------------|-------------|---------------|----------------|---------------------|---------------------|
| | A | B | C | | | | |
| 12/16 | 0.335 [7.0] | 0.385 [7.7] | 0.125 [2.2] | N/A [N/A] | N/A [N/A] | 8-32 [M4 x 0.7] | 1972-039 [3204-035] |
| 20/25 | 0.432 [10.0] | 0.487 [11.0] | 0.157 [3.2] | 1/4-28 [N/A] | 1972-015 [N/A] | 1/4-20 [M6 x 1.0] | 1972-014 [3204-001] |
| 32/40 | 0.500 [13.0] | 0.577 [14.4] | 0.187 [4.0] | 5/16-24 [N/A] | 1972-017 [N/A] | 5/16-18 [M8 x 1.25] | 1972-016 [3204-002] |
| 50/63 | 0.562 [17.0] | 0.650 [18.9] | 0.215 [5.0] | 3/8-24 [N/A] | 1972-019 [N/A] | 3/8-16 [M10 x 1.5] | 1972-018 [3204-025] |

NOTE: Numbers in [] are in mm for metric units [CRx6].

All dimensions are reference only unless specifically toleranced.

ACCESSORIES: SERIES CRS COMPACT CYLINDERS

CYLINDER PIVOT KIT

CRS

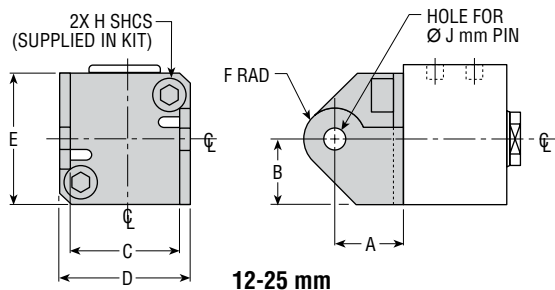

12-25 mm

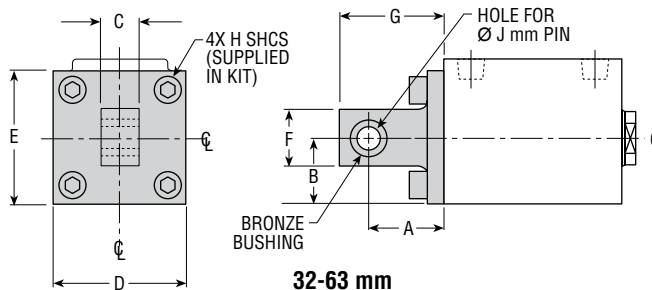

32-63 mm

| BORE [mm] | DIMENSIONS | | | | | | | | | KIT NO. IMPERIAL | KIT NO. METRIC |
|-----------|--------------|--------------|---------------|--------------|--------------|--------------|--------------|---------------------|--------------|------------------|----------------|
| | A | B | C | D | E | F | G | H | Ø J | | |
| 12 | 0.650 [16.5] | 0.638 [16.2] | 0.905 [23.00] | 1.064 [27.0] | 1.276 [32.4] | 0.281 [7.1] | — | 10-24 [M5 x 0.8] | 0.197 [5.0] | 60278-1 | 60286-1 |
| 16 | 0.650 [16.5] | 0.678 [17.2] | 0.905 [23.00] | 1.064 [27.0] | 1.356 [34.4] | 0.281 [7.1] | — | 10-24 [M5 x 0.8] | 0.197 [5.0] | 60279-1 | 60287-1 |
| 20 | 0.790 [20.1] | 0.750 [19.0] | 1.250 [31.75] | 1.500 [38.1] | 1.500 [38.1] | 0.355 [9.0] | — | 1/4-20 [M6 x 1.0] | 0.236 [6.0] | 60280-1 | 60288-1 |
| 25 | 0.790 [20.1] | 0.800 [20.3] | 1.250 [31.75] | 1.500 [38.1] | 1.600 [40.6] | 0.355 [9.0] | — | 1/4-20 [M6 x 1.0] | 0.236 [6.0] | 60281-1 | 60289-1 |
| 32 | 1.065 [27.0] | 0.935 [23.8] | 0.490 [12.45] | 1.870 [47.5] | 1.870 [47.5] | 0.820 [21.0] | 1.475 [37.5] | 1/4-20 [M6 x 1.0] | 0.394 [10.0] | 60282-1 | 60290-1 |
| 40 | 1.065 [27.0] | 1.105 [28.1] | 0.490 [12.45] | 2.210 [56.1] | 2.210 [56.1] | 0.820 [21.0] | 1.475 [37.5] | 1/4-20 [M6 x 1.0] | 0.394 [10.0] | 60283-1 | 60291-1 |
| 50 | 1.460 [37.1] | 1.300 [33.0] | 0.600 [15.24] | 2.600 [66.0] | 2.600 [66.0] | 1.000 [25.4] | 1.970 [50.0] | 5/16-18 [M8 x 1.25] | 0.472 [12.0] | 60284-1 | 60292-1 |
| 63 | 1.460 [37.1] | 1.500 [38.1] | 0.600 [15.24] | 3.000 [76.2] | 3.000 [76.2] | 1.000 [25.4] | 1.970 [50.0] | 5/16-18 [M8 x 1.25] | 0.472 [12.0] | 60285-1 | 60293-1 |

Numbers in [] are in mm for metric units [CRx6].

NOTES:

- 1) 12-25 mm IS BRITE ZINC PLATED STEEL
- 2) 32-63 mm IS ANODIZED ALUMINUM WITH LUBRICATED BRONZE BUSHINGS
- 3) FULCRUM PIN NOT INCLUDED (SEE "FULCRUM PIN KITS" TO PURCHASE)
- 4) DESIGNATED CENTERLINE \mathcal{C} IS CENTERLINE OF CYLINDER.
- 5) UNLESS OTHERWISE DIMENSIONED, FEATURES ARE CENTERED ON CYLINDER CENTERLINE.

BASE PIVOT KIT

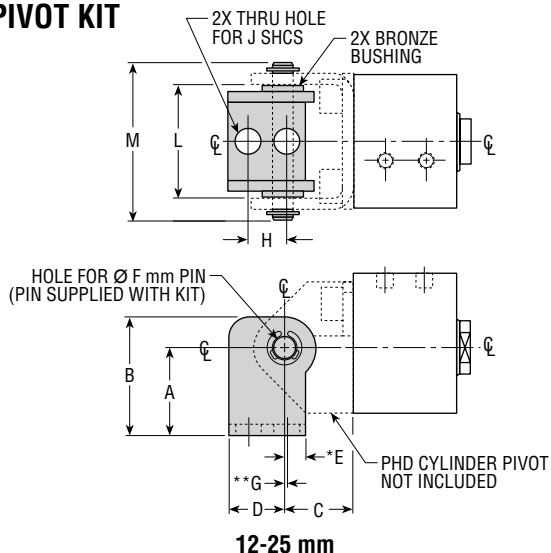

12-25 mm

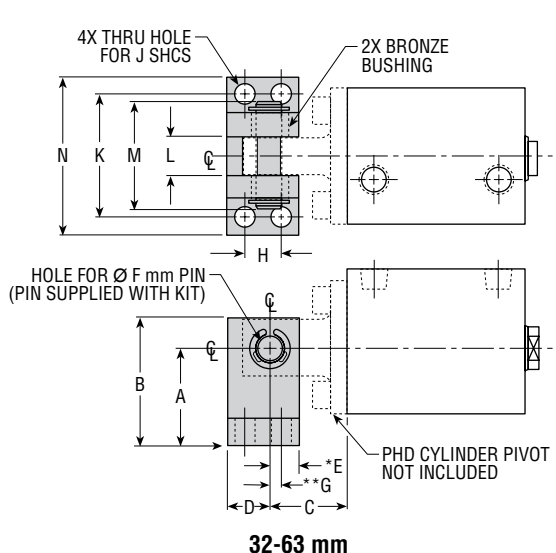

32-63 mm

| BORE [mm] | DIMENSIONS | | | | | | | | | | | | | KIT: CRx3x, CRx6x IMPERIAL/METRIC |
|-----------|--------------|--------------|--------------|--------------|--------------|--------------|-------------|--------------|-----------|--------------|--------------|--------------|--------------|-----------------------------------|
| | A | B | C | D | E | Ø F | G | H | J | K | L | M | N | |
| 12/16 | 0.865 [22.0] | 1.145 [29.0] | 0.650 [16.5] | 0.490 [12.5] | 0.220 [5.6] | 0.197 [5.0] | 0.060 [1.5] | 0.375 [9.5] | #10 [M5] | — | 0.877 [22.3] | 1.300 [33.0] | — | 60294-1 |
| 20/25 | 1.000 [25.4] | 1.355 [34.4] | 0.790 [20.1] | 0.630 [16.0] | 0.260 [6.5] | 0.237 [6.0] | 0.040 [1.0] | 0.435 [11.0] | 1/4 [M6] | — | 1.221 [31.0] | 1.730 [44.0] | — | 60295-1 |
| 32/40 | 1.375 [34.9] | 1.800 [45.7] | 1.065 [27.0] | 0.600 [15.2] | 0.400 [10.2] | 0.394 [10.0] | 0.156 [4.0] | 0.510 [13.0] | 1/4 [M6] | 1.695 [43.0] | 0.540 [13.7] | 1.490 [38.0] | 2.165 [55.0] | 60296-1 |
| 50/63 | 1.890 [48.0] | 2.365 [60.0] | 1.460 [37.1] | 0.755 [19.2] | 0.508 [12.9] | 0.472 [12.0] | 0.236 [6.0] | 0.709 [18.0] | 5/16 [M8] | 2.265 [57.5] | 0.659 [16.7] | 1.970 [50.0] | 2.835 [72.0] | 60297-1 |

Numbers in [] are in mm for metric units [CRx6].

NOTES:

- 1) 12-25 mm IS BRITE ZINC PLATED STEEL WITH LUBRICATED BRONZE BUSHINGS
- 2) 32-63 mm IS ANODIZED ALUMINUM WITH LUBRICATED BRONZE BUSHINGS
- 3) FULCRUM PIN INCLUDED. DOES NOT INCLUDE CYLINDER PIVOT.
- 4) *E IS TO CENTER OF PIVOT PIN
- 5) **G IS FROM CENTER OF PIVOT PIN TO CENTER OF FIRST MOUNTING HOLE.
- 6) DESIGNATED CENTERLINE \mathcal{C} IS CENTERLINE OF CYLINDER.

All dimensions are reference only unless specifically toleranced.

ACCESSORIES: SERIES CRS COMPACT CYLINDERS

F MOUNT KIT

(Must be ordered separately)

Plated steel for use where front or rear mounting is not feasible. Brackets are narrow allowing units to be used where space to the side of the cylinder is limited.

NOTE: Brackets may be mounted in different configurations. Each kit includes 1 bracket and cylinder mounting hardware. Two kits recommended per unit.

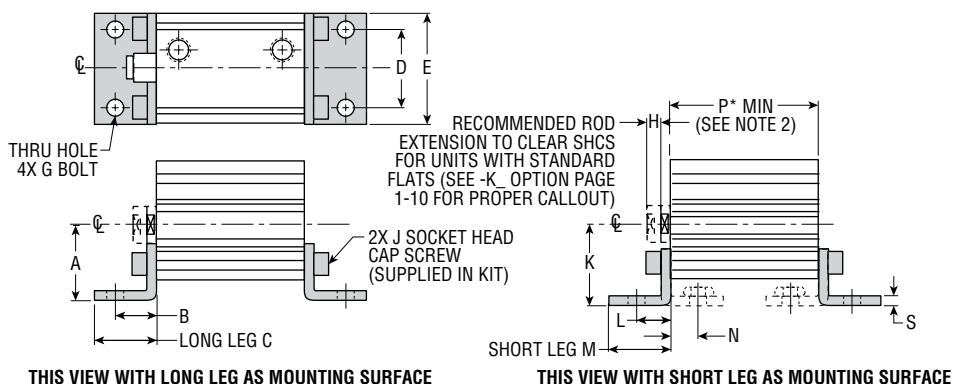

| BORE [mm] | DIMENSIONS | | | | | | | | | | | | | | KIT NO. IMPERIAL | KIT NO. METRIC |
|-----------|--------------|--------------|--------------|--------------|---------------|-----------|--------------|---------------------|--------------|--------------|--------------|--------------|------------|--------------|------------------|----------------|
| | A | B | C | D | E | G | H | J | K | L | M | N | P* MIN | S | | |
| 12 | 0.874 [22.2] | 0.553 [14.0] | 0.770 [19.6] | 0.550 [14.0] | 0.950 [24.13] | #10 [M5] | 0.250 [5.0] | 10-24 [M5 x 0.8] | 0.986 [25.0] | 0.441 [11.2] | 0.660 [17.0] | 0.336 [8.5] | 3/8 [10.0] | 0.105 [2.67] | 58904-1 | 60302-1 |
| 16 | 0.945 [24.0] | 0.589 [15.0] | 0.850 [21.6] | 0.710 [18.0] | 1.110 [28.19] | #10 [M5] | 0.250 [10.0] | 10-24 [M5 x 0.8] | 1.062 [27.0] | 0.475 [12.1] | 0.730 [18.5] | 0.355 [9.0] | 3/8 [10.0] | 0.120 [3.05] | 58905-1 | 60303-1 |
| 20 | 1.000 [25.4] | 0.680 [17.3] | 0.940 [23.9] | 1.000 [25.4] | 1.560 [39.62] | 1/4 [M6] | 0.375 [10.0] | 1/4-20 [M6 x 1.0] | 1.180 [30.0] | 0.500 [12.7] | 0.760 [19.3] | 0.380 [9.7] | 1/2 [15.0] | 0.120 [3.05] | 58906-1 | 60304-1 |
| 25 | 1.100 [27.9] | 0.690 [17.5] | 0.950 [24.1] | 1.100 [27.9] | 1.610 [40.90] | 1/4 [M6] | 0.375 [10.0] | 1/4-20 [M6 x 1.0] | 1.240 [31.5] | 0.550 [14.0] | 0.825 [21.0] | 0.415 [10.5] | 1/2 [15.0] | 0.135 [3.43] | 58907-1 | 60305-1 |
| 32 | 1.280 [32.5] | 0.730 [18.5] | 1.035 [26.3] | 1.340 [34.0] | 1.890 [48.00] | 1/4 [M6] | 0.375 [10.0] | 1/4-20 [M6 x 1.0] | 1.400 [35.5] | 0.610 [15.5] | 0.915 [23.2] | 0.446 [11.3] | 5/8 [20.0] | 0.164 [4.17] | 58908-1 | 60306-1 |
| 40 | 1.412 [35.9] | 0.807 [20.5] | 1.180 [30.0] | 1.575 [40.0] | 2.205 [56.00] | 1/4 [M6] | 0.375 [10.0] | 1/4-20 [M6 x 1.0] | 1.595 [40.5] | 0.625 [15.9] | 0.975 [24.8] | 0.446 [11.3] | 5/8 [20.0] | 0.179 [4.55] | 58909-1 | 60307-1 |
| 50 | 1.750 [44.5] | 0.905 [23.0] | 1.420 [36.1] | 1.970 [50.0] | 2.600 [66.00] | 5/16 [M8] | 0.500 [15.0] | 5/16-18 [M8 x 1.25] | 1.889 [48.0] | 0.765 [19.4] | 1.250 [31.8] | 0.556 [14.1] | 7/8 [25.0] | 0.209 [5.31] | 58910-1 | 60308-1 |
| 63 | 2.011 [51.1] | 0.985 [25.0] | 1.520 [38.6] | 2.360 [60.0] | 3.070 [78.00] | 5/16 [M8] | 0.500 [15.0] | 5/16-18 [M8 x 1.25] | 2.166 [55.0] | 0.830 [21.0] | 1.325 [33.7] | 0.580 [14.7] | 7/8 [25.0] | 0.250 [6.35] | 58911-1 | 60309-1 |

- NOTES:**
- NUMBERS IN [] ARE IN mm FOR METRIC UNITS [CRx6].
 - *MINIMUM STROKE REQUIRED FOR LEGS OF BOTH BRACKETS TO BE UNDER UNIT (SUBTRACT 0.250 [5.0] FROM P FOR MAGNETIC UNITS)
 - DESIGNATED CENTERLINE \bar{C} IS CENTERLINE OF CYLINDER.

J MOUNT KIT

(Must be ordered separately)

Plated steel for use where height is critical, but room is available to sides of unit.

NOTE: Brackets may be mounted in different configurations. Kit includes 2 brackets and cylinder mounting hardware.

NOTES:

- NUMBERS IN [] ARE IN mm FOR METRIC UNITS [CRx6].
- *MINIMUM STROKE REQUIRED FOR LEGS OF BOTH BRACKETS TO BE UNDER UNIT (SUBTRACT 0.250 [5.0] FROM P FOR MAGNETIC UNITS)
- DESIGNATED CENTERLINE \bar{C} IS CENTERLINE OF CYLINDER.

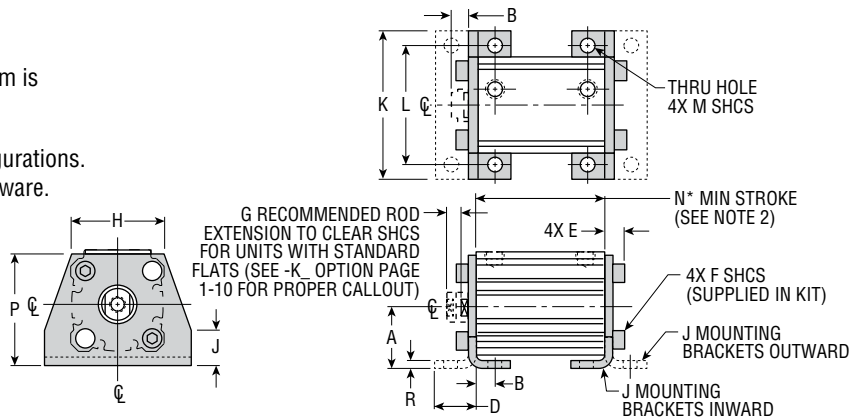

| BORE [mm] | DIMENSIONS | | | | | | | | | | | | | | KIT NO. IMPERIAL | KIT NO. METRIC |
|-----------|--------------|--------------|--------------|--------------|---------------------|--------------|--------------|--------------|---------------|--------------|-----------|--------------|--------------|--------------|------------------|----------------|
| | A | B | D | E | F | G | H | J | K | L | M | N* MIN | P | R | | |
| 12 | 0.830 [21.1] | 0.275 [7.0] | 0.600 [15.3] | 0.295 [7.5] | 10-24 [M5 x 0.8] | 0.250 [5.0] | 0.945 [24.0] | 0.390 [10.0] | 1.810 [46.0] | 1.380 [35.1] | #10 [M5] | 0.250 [5.0] | 1.510 [38.4] | 0.105 [2.67] | 60310-1 | 60318-1 |
| 16 | 0.870 [22.0] | 0.275 [7.0] | 0.610 [15.5] | 0.310 [7.9] | 10-24 [M5 x 0.8] | 0.250 [10.0] | 1.122 [28.5] | 0.450 [11.5] | 1.970 [50.0] | 1.535 [39.0] | #10 [M5] | 0.250 [5.0] | 1.620 [41.2] | 0.120 [3.05] | 60311-1 | 60319-1 |
| 20 | 0.945 [24.0] | 0.315 [8.0] | 0.710 [18.0] | 0.370 [9.4] | 1/4-20 [M6 x 1.0] | 0.375 [10.0] | 1.470 [37.4] | 0.450 [11.5] | 2.520 [64.0] | 1.969 [50.0] | 1/4 [M6] | 0.375 [10.0] | 1.750 [44.5] | 0.120 [3.05] | 60312-1 | 60320-1 |
| 25 | 1.005 [25.5] | 0.315 [8.0] | 0.725 [18.5] | 0.390 [9.9] | 1/4-20 [M6 x 1.0] | 0.375 [10.0] | 1.581 [40.2] | 0.490 [12.5] | 2.600 [66.0] | 2.047 [52.0] | 1/4 [M6] | 0.375 [10.0] | 1.890 [48.0] | 0.135 [3.43] | 60313-1 | 60321-1 |
| 32 | 1.218 [31.0] | 0.355 [9.0] | 0.834 [21.2] | 0.414 [10.5] | 1/4-20 [M6 x 1.0] | 0.375 [10.0] | 1.873 [47.6] | 0.630 [16.0] | 2.950 [75.0] | 2.362 [60.0] | 1/4 [M6] | 0.375 [10.0] | 2.240 [57.0] | 0.164 [4.17] | 60314-1 | 60322-1 |
| 40 | 1.400 [35.6] | 0.355 [9.0] | 0.885 [22.5] | 0.429 [10.9] | 1/4-20 [M6 x 1.0] | 0.375 [10.0] | 2.190 [55.7] | 0.670 [17.0] | 3.310 [84.1] | 2.677 [68.0] | 1/4 [M6] | 0.500 [10.0] | 2.560 [65.0] | 0.179 [4.55] | 60315-1 | 60323-1 |
| 50 | 1.730 [44.0] | 0.492 [12.5] | 1.110 [28.2] | 0.531 [13.5] | 5/16-18 [M8 x 1.25] | 0.500 [15.0] | 2.577 [65.5] | 0.850 [21.5] | 3.940 [100.1] | 3.189 [81.0] | 5/16 [M8] | 0.625 [15.0] | 3.150 [80.0] | 0.209 [5.31] | 60316-1 | 60324-1 |
| 63 | 2.010 [51.1] | 0.512 [13.0] | 1.250 [31.8] | 0.570 [14.5] | 5/16-18 [M8 x 1.25] | 0.500 [15.0] | 3.055 [77.6] | 1.000 [25.5] | 4.530 [115.1] | 3.661 [93.0] | 5/16 [M8] | 0.750 [20.0] | 3.660 [93.0] | 0.250 [6.35] | 60317-1 | 60325-1 |

All dimensions are reference only unless specifically toleranced.

ACCESSORIES: SERIES CRS COMPACT CYLINDERS

ROD EYE KIT

| BORE [mm] | DIMENSIONS | | | | | | KIT: CRx3x IMPERIAL | KIT: CRx6x METRIC |
|-----------|-----------------|-----------------|-----------------|-----------------|------------------------|-----------------|---------------------|-------------------|
| | A | B | C | D | F | G | | |
| 12/16 | 0.438 [11.0] | 0.250 [6.5] | 0.885 [22.5] | 0.215 [5.5] | 8-32 [M4 x 0.7] | 0.197 [5.0] | 59069-1 | 60234-1 |
| 20/25 | 0.500 [12.7] | 0.375 [9.5] | 1.065 [27.0] | 0.255 [6.5] | 1/4-28 [M6 x 1.0] | 0.236 [6.0] | 59070-1 | 60235-1 |
| 32/40 | 0.625 [16.0] | 0.500 [12.5] | 1.495 [38.0] | 0.355 [9.0] | 5/16-24 [M8 x 1.25] | 0.394 [10.0] | 59071-1 | 60236-1 |
| 50/63 | 0.875 [22.2] | 0.625 [16.0] | 1.610 [41.0] | 0.430 [11.0] | 3/8-24 [M10 x 1.5] | 0.472 [12.0] | 59072-1 | 60237-1 |

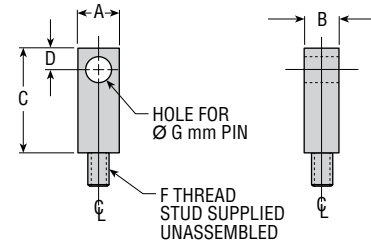

NOTES:

- 1) UNIT MUST BE ORDERED WITH STANDARD FEMALE THREADS
- 2) DESIGNATED CENTERLINE \mathcal{C} IS CENTERLINE OF PART. ALL FEATURES CENTERED ON \mathcal{C} UNLESS OTHERWISE NOTED.
- 3) STANDARD PLATING IS BRITE ZINC
- 4) NUMBERS IN [] ARE IN mm FOR METRIC UNITS [CRx6]

ROD CLEVIS KIT

| BORE [mm] | DIMENSIONS | | | | | | | | | | KIT: CRx3x IMPERIAL | KIT: CRx6x METRIC |
|-----------|-----------------|-----------------|-----------------|-----------------|-----------------|-----------------|-----------------|------------------------|-----------------|---------|---------------------|-------------------|
| | A | B | C | D | F | G | H | J | K | | | |
| 12/16 | 0.438 [11.0] | 0.625 [15.9] | 1.000 [25.4] | 0.215 [5.5] | 0.266 [6.8] | 0.610 [15.5] | 0.197 [5.0] | 8-32 [M4 x 0.7] | 0.845 [21.5] | 59073-1 | 60238-1 | |
| 20/25 | 0.500 [12.7] | 0.750 [19.0] | 1.255 [32.0] | 0.255 [6.5] | 0.391 [9.9] | 0.738 [18.8] | 0.236 [6.0] | 1/4-28 [M6 x 1.0] | 0.965 [24.5] | 59074-1 | 60239-1 | |
| 32/40 | 0.625 [15.9] | 1.000 [25.4] | 1.615 [41.0] | 0.315 [8.0] | 0.518 [13.2] | 0.925 [23.5] | 0.394 [10.0] | 5/16-24 [M8 x 1.25] | 1.300 [33.0] | 59075-1 | 60240-1 | |
| 50/63 | 0.875 [22.2] | 1.250 [31.8] | 1.815 [46.1] | 0.435 [11.0] | 0.645 [16.4] | 1.165 [29.6] | 0.472 [12.0] | 3/8-24 [M10 x 1.5] | 1.575 [40.0] | 59076-1 | 60241-1 | |

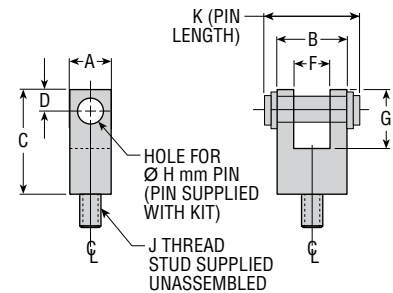

NOTES:

- 1) UNIT MUST BE ORDERED WITH STANDARD FEMALE THREADS
- 2) DESIGNATED CENTERLINE \mathcal{C} IS CENTERLINE OF PART. ALL FEATURES CENTERED ON \mathcal{C} UNLESS OTHERWISE NOTED.
- 3) STANDARD PLATING IS BRITE ZINC (PIN & CLEVIS)
- 4) NUMBERS IN [] ARE IN mm FOR METRIC UNITS [CRx6]

ROD FULCRUM PIN KIT

Replacement for Rod Clevis pin or for use with PHD Rod Eye. Pin is Brite Zinc plated. Retaining rings are supplied.

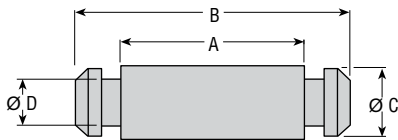

| BORE [mm] | DIMENSIONS | | | | KIT: CRx3x, CRx6x IMPERIAL/METRIC |
|-----------|-----------------|-----------------|-----------------|-----------------|-----------------------------------|
| | A | B | $\varnothing C$ | $\varnothing D$ | |
| 12/16 | 0.665 [16.9] | 0.845 [21.5] | 0.197 [5.0] | 0.125 [3.2] | 60326-1 |
| 20/25 | 0.785 [19.9] | 0.965 [24.5] | 0.236 [6.0] | 0.156 [4.0] | 60327-1 |
| 32/40 | 1.045 [26.5] | 1.300 [33.0] | 0.394 [10.0] | 0.274 [7.0] | 60328-1 |
| 50/63 | 1.295 [32.9] | 1.575 [40.0] | 0.472 [12.0] | 0.353 [9.0] | 60329-1 |

NOTE: Numbers in [] are in mm for metric units [CRx6].

CYLINDER FULCRUM PIN KIT

Replacement for base pivot pin or for use with PHD Cylinder Pivot. Pin is Brite Zinc plated. Retaining rings are supplied.

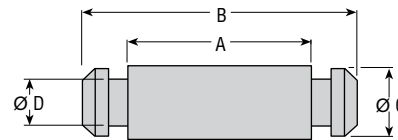

| BORE [mm] | DIMENSIONS | | | | KIT: CRx3x, CRx6x IMPERIAL/METRIC |
|-----------|-----------------|-----------------|-----------------|-----------------|-----------------------------------|
| | A | B | $\varnothing C$ | $\varnothing D$ | |
| 12/16 | 1.120 [28.5] | 1.300 [33.0] | 0.197 [5.0] | 0.125 [3.1] | 60330-1 |
| 20/25 | 1.550 [39.4] | 1.730 [44.0] | 0.236 [6.0] | 0.156 [4.0] | 60331-1 |
| 32/40 | 1.240 [31.5] | 1.490 [37.9] | 0.394 [10.0] | 0.274 [7.0] | 60332-1 |
| 50/63 | 1.690 [42.9] | 1.970 [50.0] | 0.472 [12.0] | 0.353 [9.0] | 60333-1 |

NOTE: Numbers in [] are in mm for metric units [CRx6].

All dimensions are reference only unless specifically toleranced.