

ML321060 Exhaust Cylinder

Benefits

- Drop in upgrade for ML318013
- 40% more exhaust flow
- Engineered seal and shock pad upgrades for longer life
- Blunt rod end reduces clog and provides greater seal
- Quick exhaust of mold air on a continuous extrusion wheel

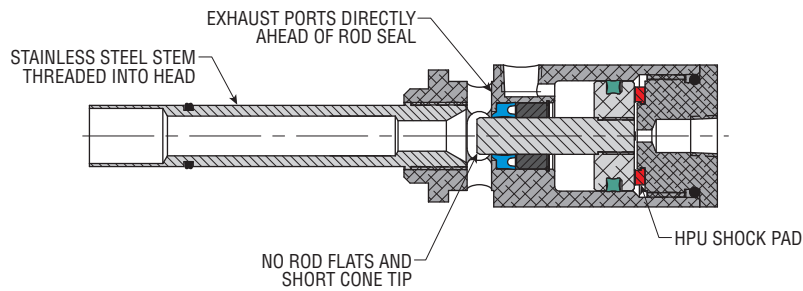
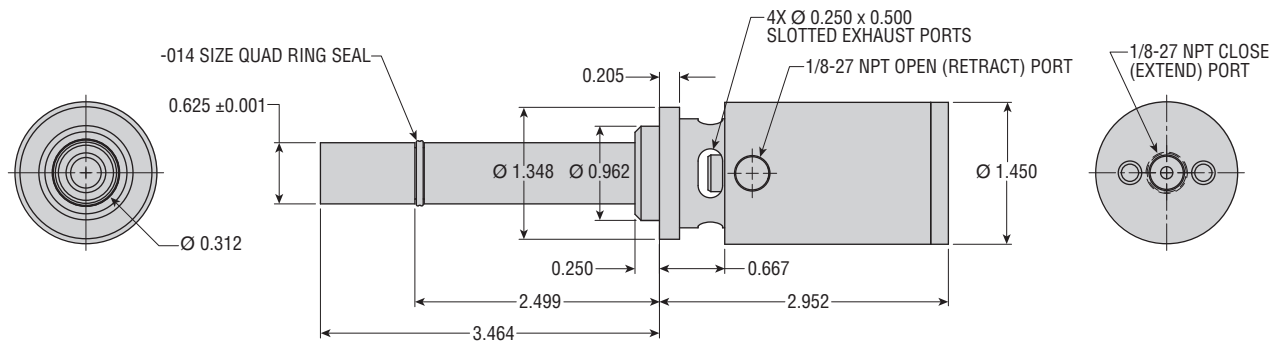
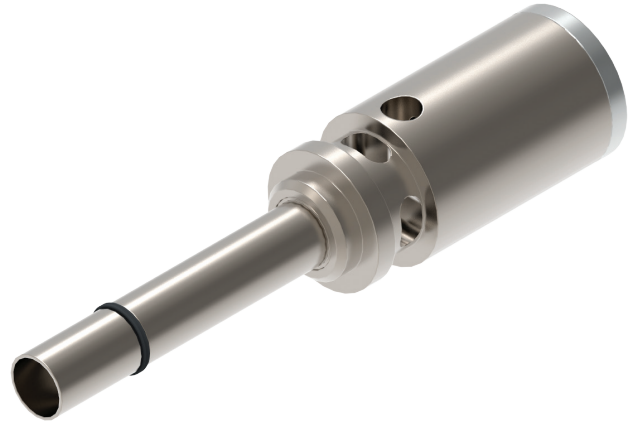

All dimensions are reference only unless specifically toleranced.

© Copyright 2026, by PHD, Inc. All Rights Reserved. Printed in the U.S.A.

2/26 11962