

ML315476 Glass Tong Head Gripper

Major Benefits

- Mechanical Locking: Gripper jaws are locked on full open, thus eliminating jaws and tooling being exposed to additional moments of inertia during gob/bottle transfer onto the conveyor
- Very Precise Jaw Movement: For consistent, repeatable pick up. No pin breaks or jaw play!
- Drop-in Replacement: Replaces Vitro and other glass bottle forming machines
- Mechanical locking (Anti-Wink): Gripper jaws are locked on full open, thus preventing jaws from moving while open
- Less Downtime: Designed for more than 10 million cycles
- Easily field repairable, spare parts available upon request



SPECIFICATIONS	ML315476
WEIGHT	37 oz [1049 g]
BORE	1.250 in [31.75 mm]
JAWS OPEN ANGLE	32.7°
JAWS FULL CLOSE	Jaws are parallel
JAW MATERIAL	Pre-hardened steel
BODY	Coated
SPRING OPEN	Spring installed in customer casting

Dimensions

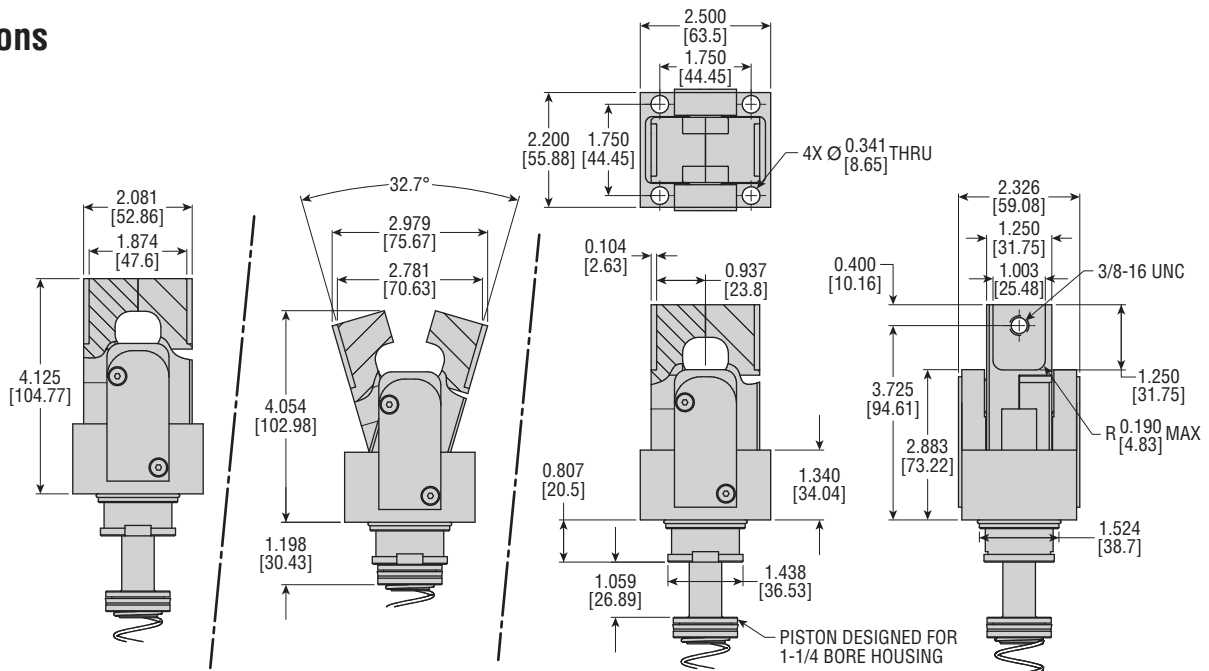

- NOTES:
- 1) ALL DIMENSIONS ARE FOR REFERENCE ONLY
 - 2) SINGLE ACTING OPERATION: -SPRING OPEN; AIR PRESSURE CLOSED
 - 3) CUSTOMER TO VERIFY ALL DIMENSIONS

All dimensions are reference only unless specifically tolerated.

