



Rotary Actuator for Solar Panel Manufacturing

ML #309840

BENEFITS

- High torque, heavy duty
- Wide variety of options and accessories
- Free floating aluminum pistons with pressure and wear compensating piston seals provide long life and low friction
- Heavy duty sealed ball bearings ensure shaft stability under heavy and high impact loading
- Double rack for increased torque capability
- Output torque at 5100 in-lb at 90 psi



APPLICATION

The rotary actuator is used to close a door on a vacuum chamber. It is critical that the force of the rotary can withstand the force of the chamber.

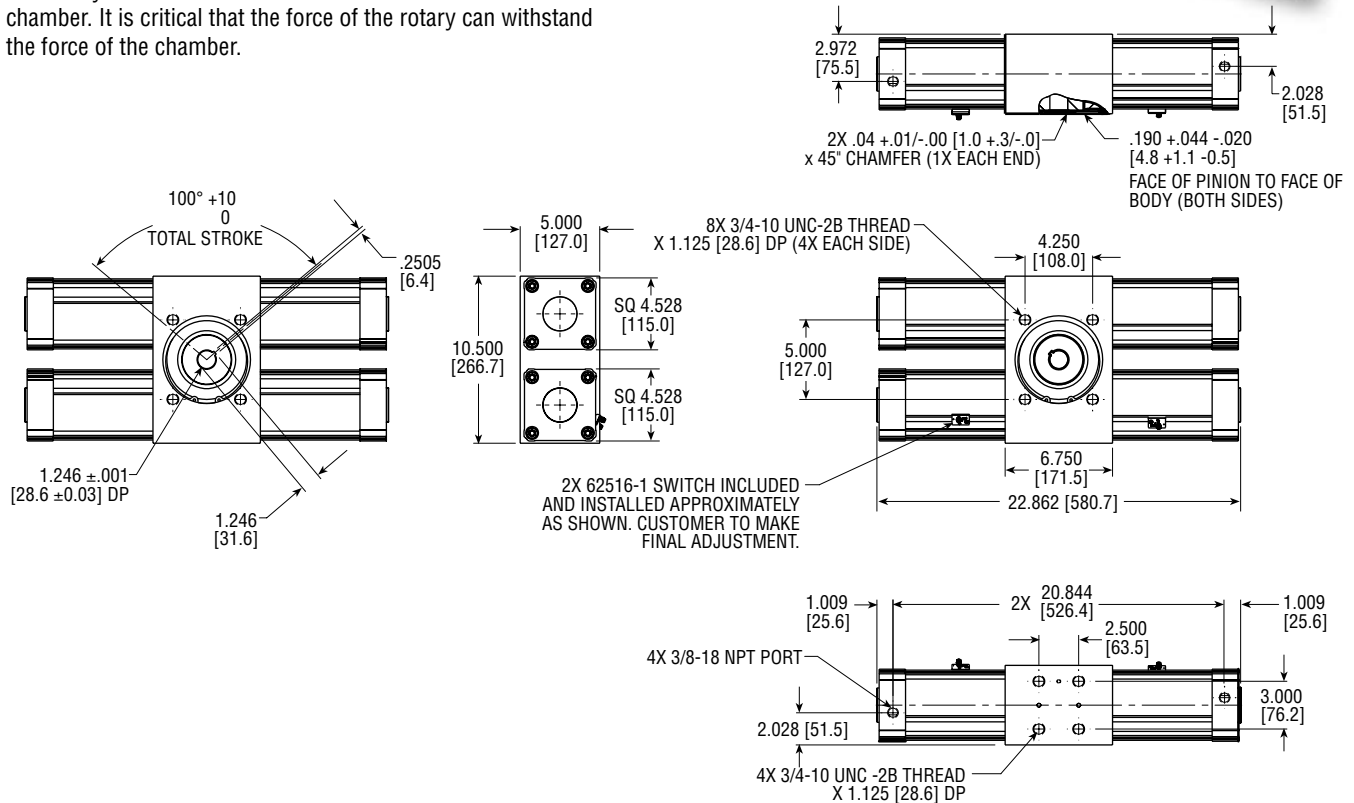

© Copyright 2009, by PHD, Inc. All Rights Reserved. Printed in the U.S.A.

CP309840



PHD is a member of the
MAC Distributor Network



PHD, Inc. • P.O. Box 9070 • Fort Wayne, IN 46899 • (260) 747-6151 • FAX (260) 747-6754
www.phdinc.com • phdinfo@phdinc.com