



Staging Stop

ML# 307537

BENEFITS

- Direct replacement
- Pawl locks in up position (even with loss of air pressure)
- Two sets of switch mounting locations
- Field repairable
- Rebuild and seal kits available
- Rated life: 2 million cycles @ .5 lbf-in kinetic energy absorption
- Designed and manufactured by PHD, Inc. USA - Over 45 years of automation solutions experience.



SPECIFICATIONS

Stop Arm	Hardened Tool Steel
Body	Hardcoat Aluminum
Weight	.36 lb [.16 Kg]
Air Pressure:	
Maximum	150 psi [10 bar]
Minimum	25 psi [1.7 bar]
Lubrication	Permanent for clean dry air

DIMENSIONS

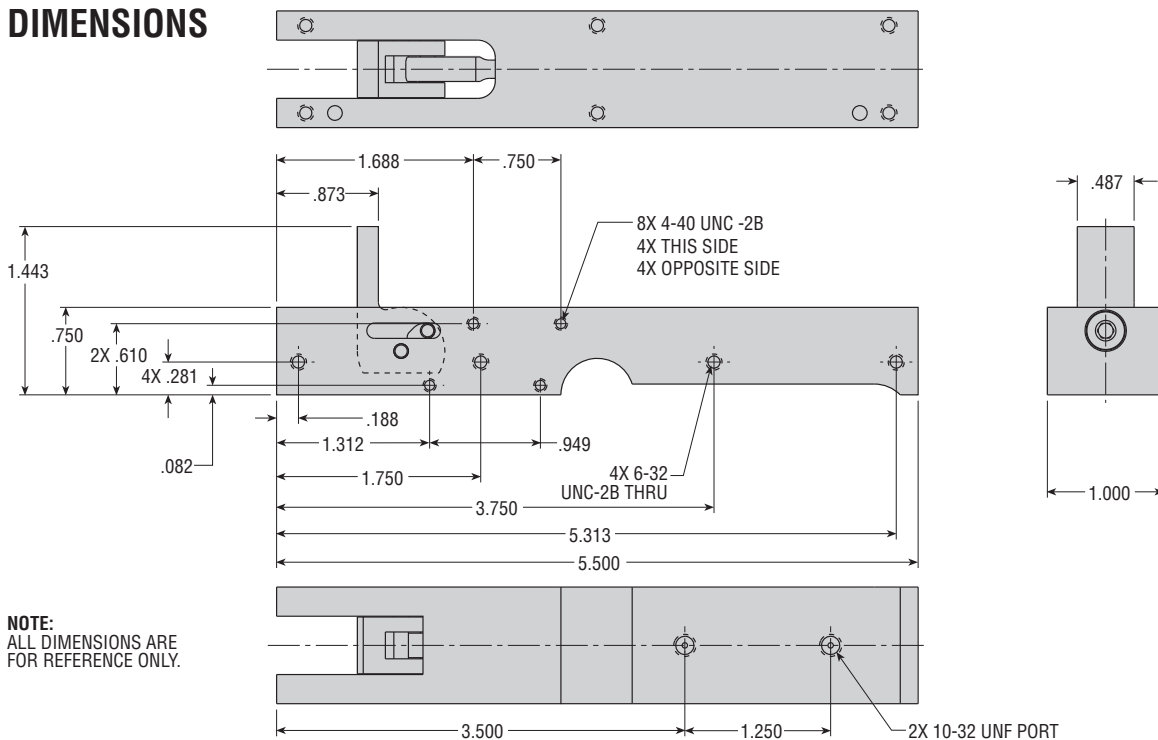

CP307537

© Copyright 2011, by PHD, Inc.



PHD is a member of the
MAC Distributor Network

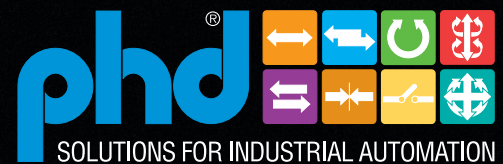

PHD, Inc. • P.O. Box 9070 • Fort Wayne, IN 46899 • (260) 747-6151 • FAX (260) 747-6754
www.phdinc.com • phdinfo@phdinc.com