



Corrosion Resistant Plastic Slide

ML#305733

BENEFITS

- 100% corrosion resistant
- Materials used - PET & stainless steel
- Purge / Vacuum port
- Rod scrapers
- No grooves in body
- Stainless steel mounting insert
- Lightweight slide
- Large guide shafts
- Dual bore slide



UNIT FEATURES

Bore Size: 2X 32mm DIA
Stroke: 2.000 +.080/- .000 in [50 mm]
Body: PET
Toolplate: PET
Guidesh shafts: Chrome-plated stainless steel with scrapers
Retaining Rings: Stainless steel
Fasteners: Stainless steel
(OTHER CONFIGURATIONS ARE AVAILABLE)

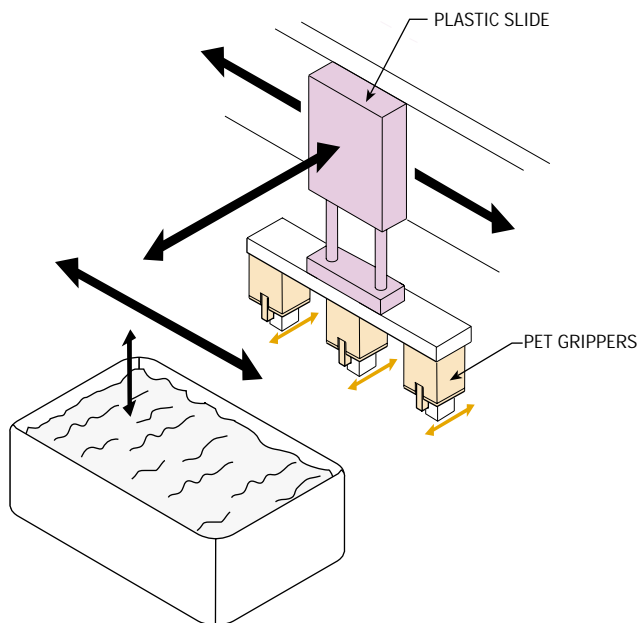

© Copyright 2005, by PHD, Inc.

CP305733



SOLUTIONS FOR INDUSTRIAL AUTOMATION

PHD, Inc. • P.O. Box 9070 • Fort Wayne, IN 46899 • (260) 747-6151 • FAX (260) 747-6754
www.phdinc.com • phdinfo@phdinc.com

DIMENSIONS: Corrosion Resistant Plastic Slide

ML#305733

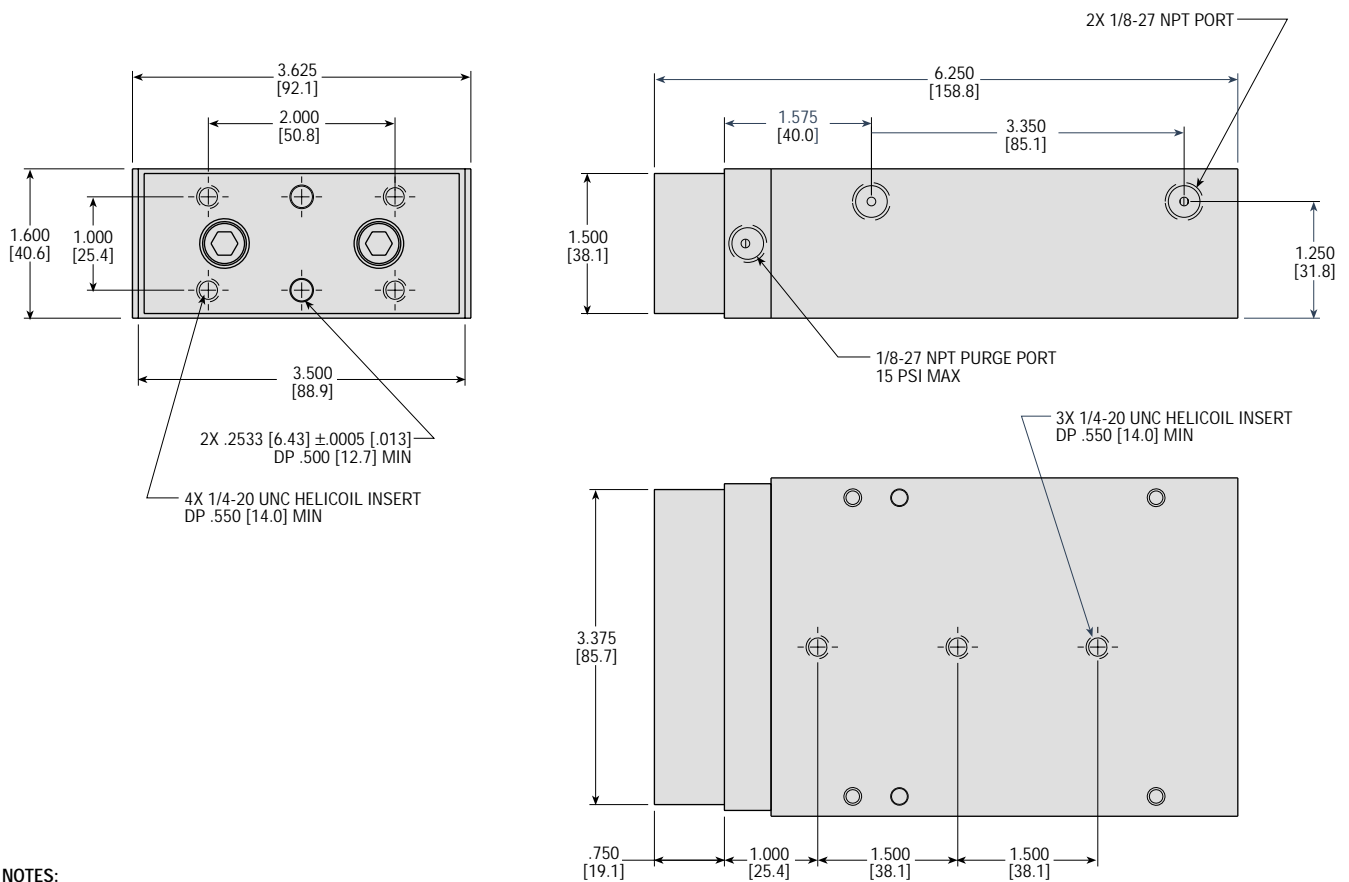
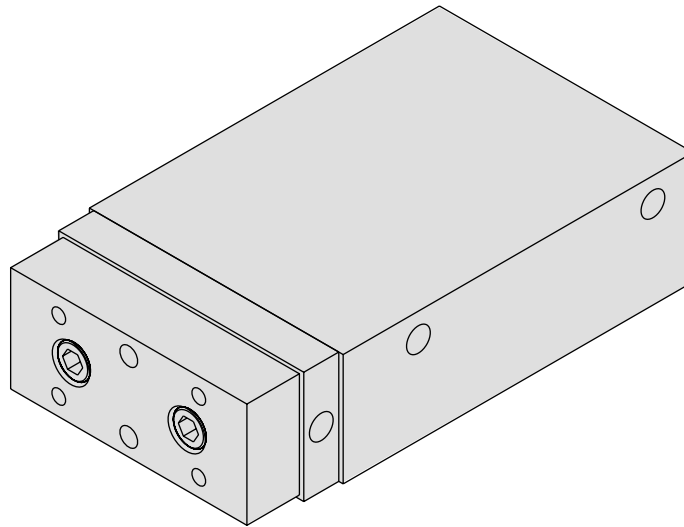

NOTES:

- 1) ALL DIMENSIONS ARE REFERENCE UNLESS SPECIFICALLY TOLERANCED
- 2) DIMENSION UNITS ARE INCHES [mm]

© Copyright 2005, by PHD, Inc.

PHD, Inc.
 9009 Clubridge Drive
 P.O. Box 9070, Fort Wayne, Indiana 46899 U.S.A.
 Phone (260) 747-6151 • Fax (260) 747-6754
 phdinfo@phdinc.com • www.phdinc.com

PHD GmbH
 Arnold-Sommerfeld-Ring 2
 52499 Baesweiler, Germany
 Tel. +49 (0) 2401 805 230 • Fax +49 (0) 2401 805 232
 solutions@phd-gmbh.de

CP305733